

YAMAHA

PARTS CATALOGUE

YZ80B (3MK3/3MM3)

**U.S.A., CANADA,
NEWZEALAND, S.AFRICA**

(13MK-100E1

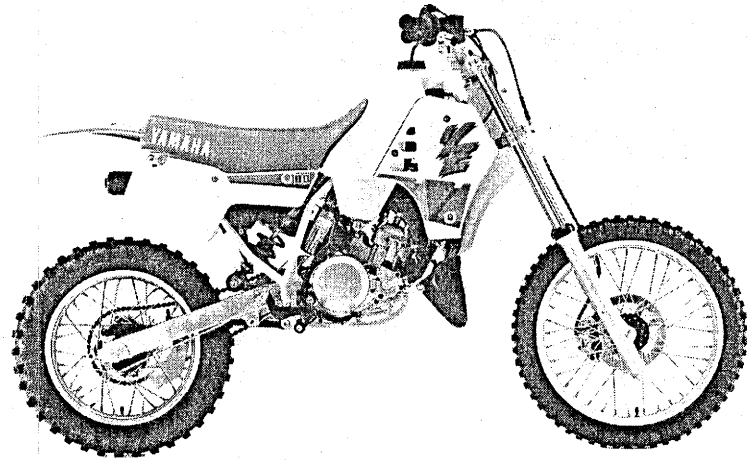

A3

FOREWORD

This Parts Catalogue is related to the parts in use for the Yamaha YZ80B(3MK3/3MM3). When you are ordering replacement parts for the YZ80B(3MK3/3MM3), refer to this Parts Catalogue and quote both part numbers and part names correctly.

1. Modifications or additions which have been made after issue of the Parts Catalogue will be announced in the Yamaha Parts News. It is advisable that according to the Yamaha Parts News you make necessary corrections to the Parts Catalogue on hand to keep it up-to-date.

2. Abbreviations

The following abbreviations are used in this Parts Catalogue.

- U.R. Use size (thickness) and/or number as required.
- U.N. Use as many as you need.
- A.P. Alternate Parts
- L.M. Local Made
- F# Frame No. (Applicable machine No.)

3. The parts marked with (+) in the parts number column of this Catalogue are not supplied with by Yamaha, those have to be found locally.
4. Parts, which are to be supplied in the form of assemblies, are listed with an indention of one letter's space, and a dot (.) is put against the name of each part.

EXAMPLE CARBURETOR ASS'Y
 . JET, pilot
 . NOZZLE, main

5. Indication of No. of constituent parts for assembly

The numeral appearing to the right of each constituent part under the description indicates the quantity of such parts for each individual assembly unit.

EXAMPLE

Part No.	Description	Q'ty	Remarks
2F5-83310-60	FRONT FLASHER LIGHT ASS'Y	2	
115-83311-60	. BULB (6V-18W)	1	
1M1-83309-60	. REFLECTOR	1	

6. Initial Serial No. and Color Code

3MK3	(A) Frame Serial No.	3MK-000101 and following
	(B) Engine Serial No.	3MK-000101 and following

3MM3	(A) Frame Serial No.	3MM-003101 and following
	(B) Engine Serial No.	3MM-003101 and following

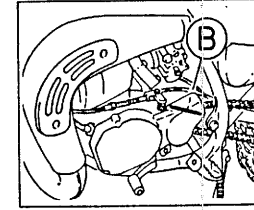
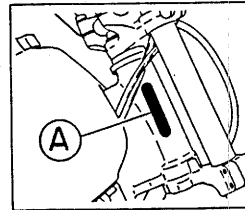

Color Code	Color Name	Abbreviate
0206	PURPLISH WHITE SOLID 1	PWS 1

7. Applicable colors of graphics are represented in the "Remarks" column by the letter(s) appropriately picked out of the full word(s) showing such colors.

EXAMPLE

Part No.	Description	Q'ty	Remarks
2N4-24110-00-X5	FUEL TANK COMP.	1	MAXIM RED
3J1-24240-10	. GRAPHIC, fuel tank set	1	for MXR

CONTENTS

ENGINE

Cylinder	B2
Crankshaft. Piston	B3
Water Pump	B4
Radiator. Hose	B5
Intake	B6 ~ B7
Carburetor	B8 ~ B9
Exhaust	B10
Crankcase	B11
Crankcase Cover 1	B12
Starter	B13
Clutch	B14
Transmission	B15
Shift Cam. Fork	C2
Shift Shaft	C3

CHASSIS

Frame	C4
Fender	C5
Side Cover	C6
Rear Arm	C7 ~ C8
Rear Suspension	C9
Steering	C10
Front Fork	C11 ~ C12
Fuel Tank	C13 ~ C14
Seat	C15
Front Wheel	D2
Front Brake Caliper	D3
Rear Wheel	D4 ~ D5
Steering Handle. Cable	D6

Front Master Cylinder	D7
Stand. Footrest	D8 ~ D9
Generator	D10
Handle Switch. Lever	D11
Electrical 1	D12

ALTERNATE PARTS

Alternate 1 (Chassis)	D13
-----------------------------	-----

REPAIR KIT

Repair Kit	D14
------------------	-----

INDEX

Numerical Index	M1 ~ M3
-----------------------	---------

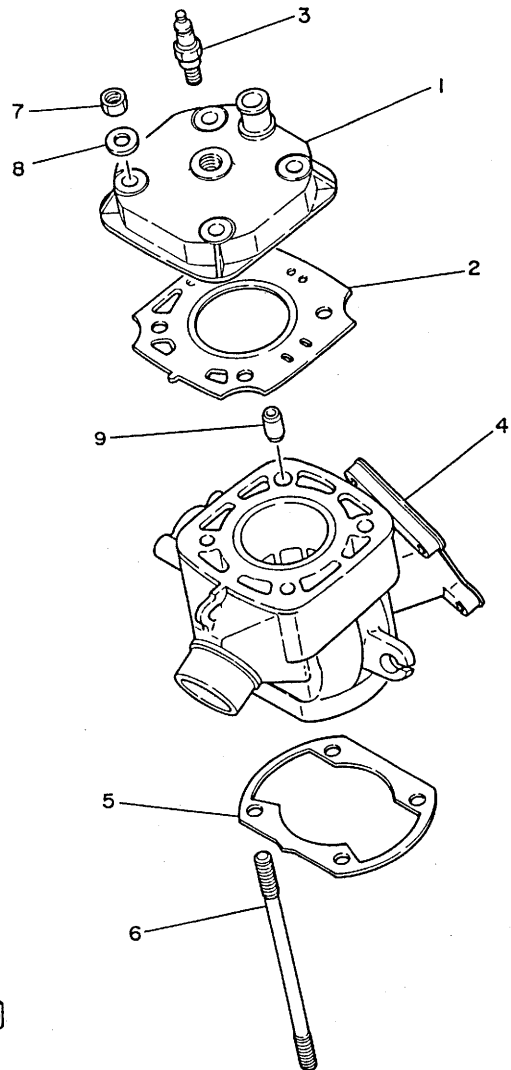

FIG. 1 CYLINDER

REF. NO.	PART NO.	DESCRIPTION	Q'TY	REMARKS
1	2VE-11111-00	HEAD, cylinder 1	1	
2	1LR-11181-00	GASKET, cylinder head 1	1	
3	94702-00325	PLUG, spark (NGK B9EG)	1	UR FOR U.S.A., NEWZEALAND
	94702-00324	PLUG, spark (NGK BR9EG)	1	UR FOR CANADA, S.AFRICA
4	2HF-11311-01	CYLINDER 1	1	
5	4V0-11351-00	GASKET, cylinder	1	
6	90116-08402	BOLT, stud	4	
7	90176-08026	NUT, crown	4	
8	90201-08087	WASHER, plate	4	
9	99510-10114	PIN, dowel	2	



2HF100-7010

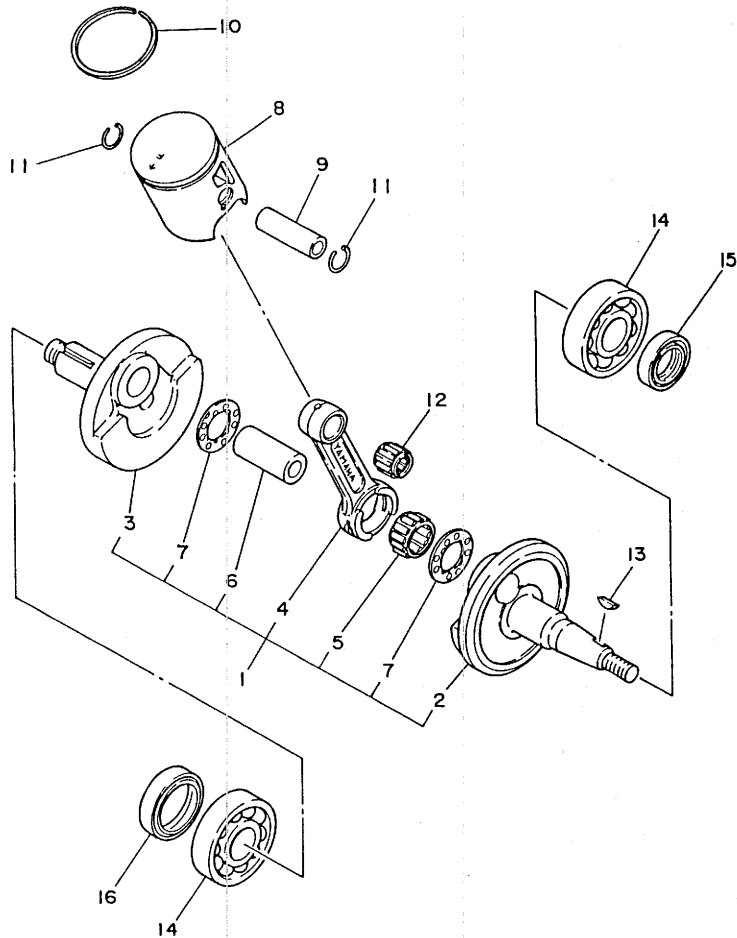

FIG. 2 CRANKSHAFT. PISTON

REF. NO.	PART NO.	DESCRIPTION	Q'TY	REMARKS
1	1LR-11400-00	CRANKSHAFT ASSY	1	
2	39K-11412-00	.CRANK 1	1	
3	39K-11422-00	.CRANK 2	1	
4	1LR-11651-00	.ROD, connecting	1	
5	93310-418M6	.BEARING, cylindrical	1	
6	4V0-11681-00	.PIN, crank 1	1	
7	90209-18112	.WASHER	2	
8	2VE-11631-00-94	PISTON (STD)	1	UR
	2VE-11631-00-95	PISTON (STD)	1	UR
	2VE-11635-00	PISTON (0.25MM O/S)	1	AP
	2VE-11636-00	PISTON (0.50MM O/S)	1	AP
9	4V1-11633-00	PIN, piston	1	
10	39K-11611-00	RING, piston	1	STD
	39K-11611-10	RING, piston	1	AP
	39K-11611-20	RING, piston	1	AP
11	93450-13130	CIRCLIP	2	
12	93310-312M5	BEARING, cylindrical	1	
13	90280-03045	KEY, woodruff	1	
14	93306-20454	BEARING	2	
15	93102-20231	OIL SEAL	1	
16	93103-28126	OIL SEAL	1	



2VF010-8020

B3

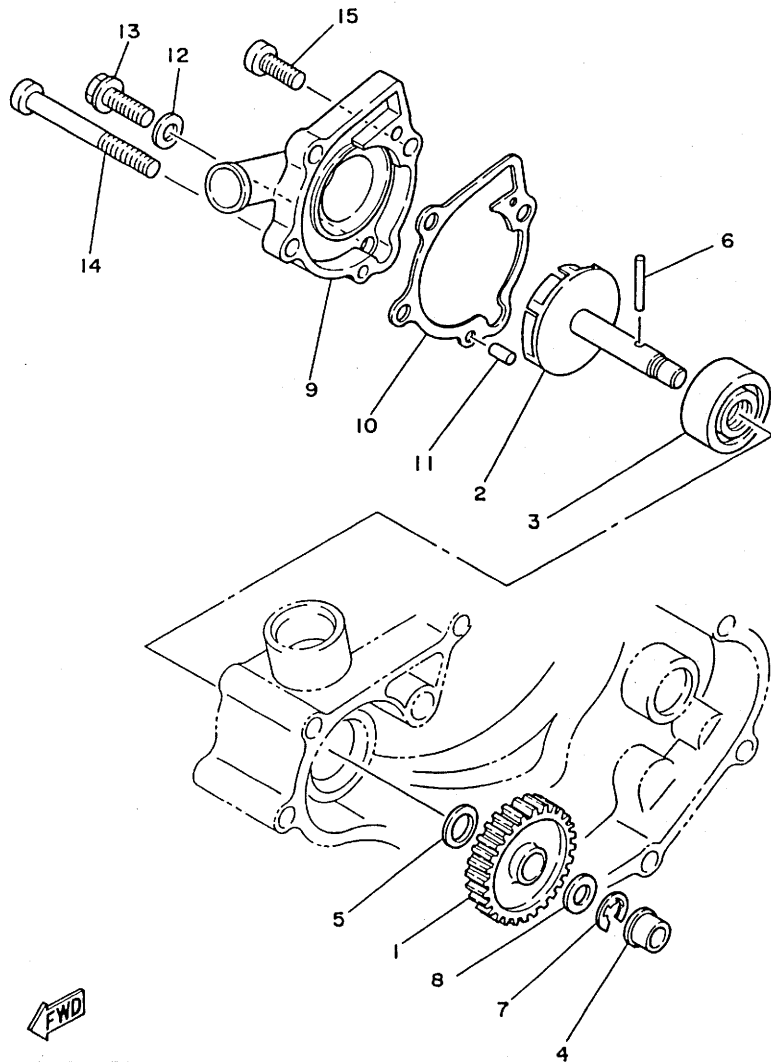

FIG. 3 WATER PUMP

REF. NO.	PART NO.	DESCRIPTION	Q'TY	REMARKS
1	11R-12459-00	GEAR, impeller shaft	1	
2	22W-12450-00	IMPELLER SHAFT ASSY	1	
3	93103-10147	OIL SEAL	1	
4	90381-08002	BUSH, solid	1	
5	90201-10614	WASHER, plate	1	
6	93603-22028	PIN, dowel	1	
7	99080-07600	CIRCLIP	1	
8	90201-08085	WASHER, plate	1	
9	2VE-12422-00	COVER, housing	1	
10	5X2-12428-00	GASKET, housing cover 2	1	
11	93604-10011	PIN, dowel	2	
12	90430-06166	GASKET	1	
13	95826-06020	BOLT, flange	1	
14	92506-06060	SCREW, pan head	2	
15	98516-06020	SCREW, pan head	1	



39K100-4030

B4

FIG. 4 RADIATOR. HOSE

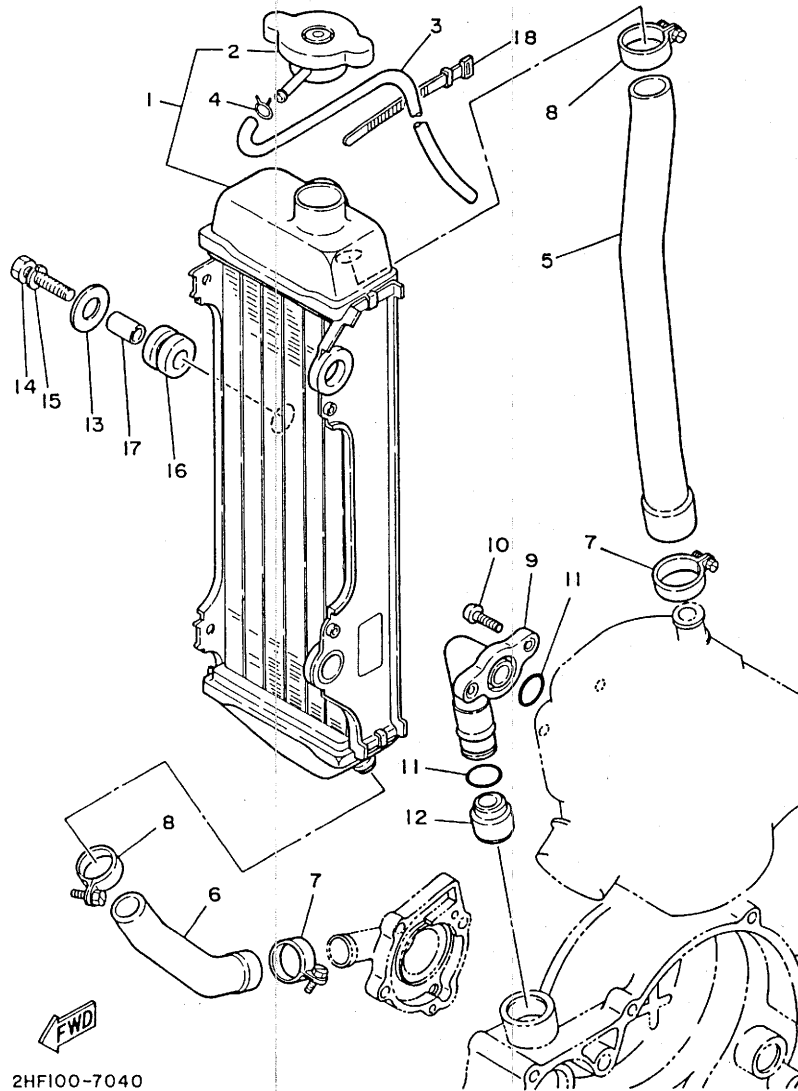

2HF100-7040

REF. NO.	PART NO.	DESCRIPTION	Q'TY	REMARKS
1	2HF-12460-00	RADIATOR ASSY	1	
2	22W-12462-00	.CAP, radiator	1	
3	22W-12463-00	PIPE, breather	1	
4	90467-08004	CLIP	1	
5	39K-12481-00	PIPE 1	1	
6	39K-12482-00	PIPE 2	1	
7	90450-28014	HOSE CLAMP ASSY	2	
8	90450-22017	HOSE CLAMP ASSY	2	
9	2VE-12446-00	JOINT	1	
10	92506-06016	SCREW, pan head	2	
11	93210-16275	O-RING	2	
12	4V2-12494-00	SEAL, pipe 1	1	
13	90201-061H3	WASHER, plate	3	
14	97001-06030	BOLT	3	
15	92990-06100	WASHER, spring	3	
16	90480-15064	GROMMET	3	
17	90387-07392	COLLAR	3	
18	437-83936-01	BAND, switch cord	1	

B5

FIG. 5 INTAKE

REF. NO.	PART NO.	DESCRIPTION	Q'TY	REMARKS
1	2HF-13610-01	REED VALVE ASSY	1	
2	2HF-13613-00	.REED, valve	2	
3	58T-13616-01	.STOPPER, reed valve	2	
4	98580-03008	.SCREW, pan head	4	
5	92990-03100	.WASHER, spring	4	
6	1LR-13621-00	GASKET, valve seat	1	
7	1LR-13565-00	JOINT, carburetor	1	
8	95026-06020	BOLT, flange	4	
9	90460-43053	CLAMP, hose	1	
10	90460-51059	CLAMP, hose	1	
11	2HF-14453-00	JOINT, air cleaner 1	1	
12	2HF-14459-00	HOLDER, guide	1	
13	2HF-14462-00	SEAL	1	
14	39K-14457-00	SEAL	1	
15	90504-03033	SPRING, compression	1	
16	2HF-W1441-00	AIR CLEANER CASE COMP.	1	
17	2HF-14477-00	PLATE	1	
18	95601-05100	NUT, u	6	
19	2HF-14451-00	ELEMENT, air cleaner	1	
20	2HF-14458-00	GUIDE	1	
21	90122-06013	BOLT, wing	1	
22	90209-06096	WASHER	1	
23	97013-06012	BOLT	1	
24	92990-06100	WASHER, spring	1	
25	22W-13581-00	CHAMBER, air	1	
26	90445-164E1	HOSE	1	
27	90467-16063	CLIP	2	
28	90159-06033	SCREW, with washer	1	

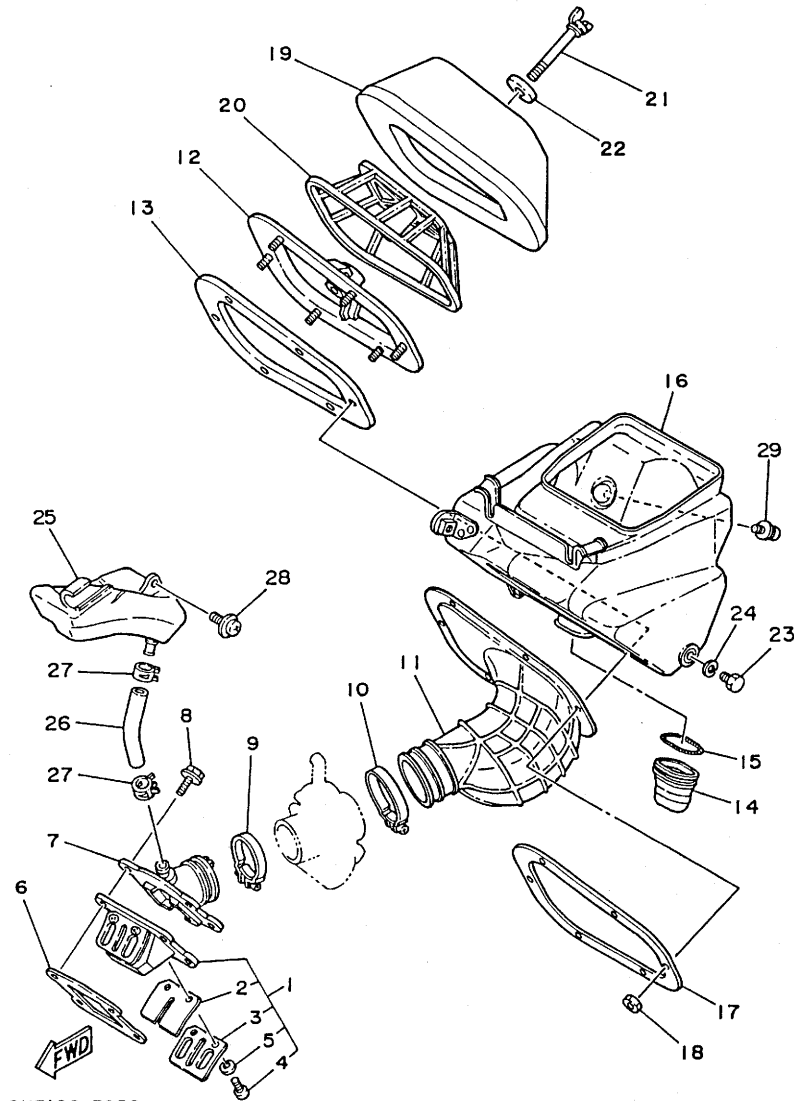

2HF100-7050

FIG. 5 INTAKE

REF. NO.	PART NO.	DESCRIPTION	Q'TY	REMARKS
29	90119-06085	BOLT, with washer	1	

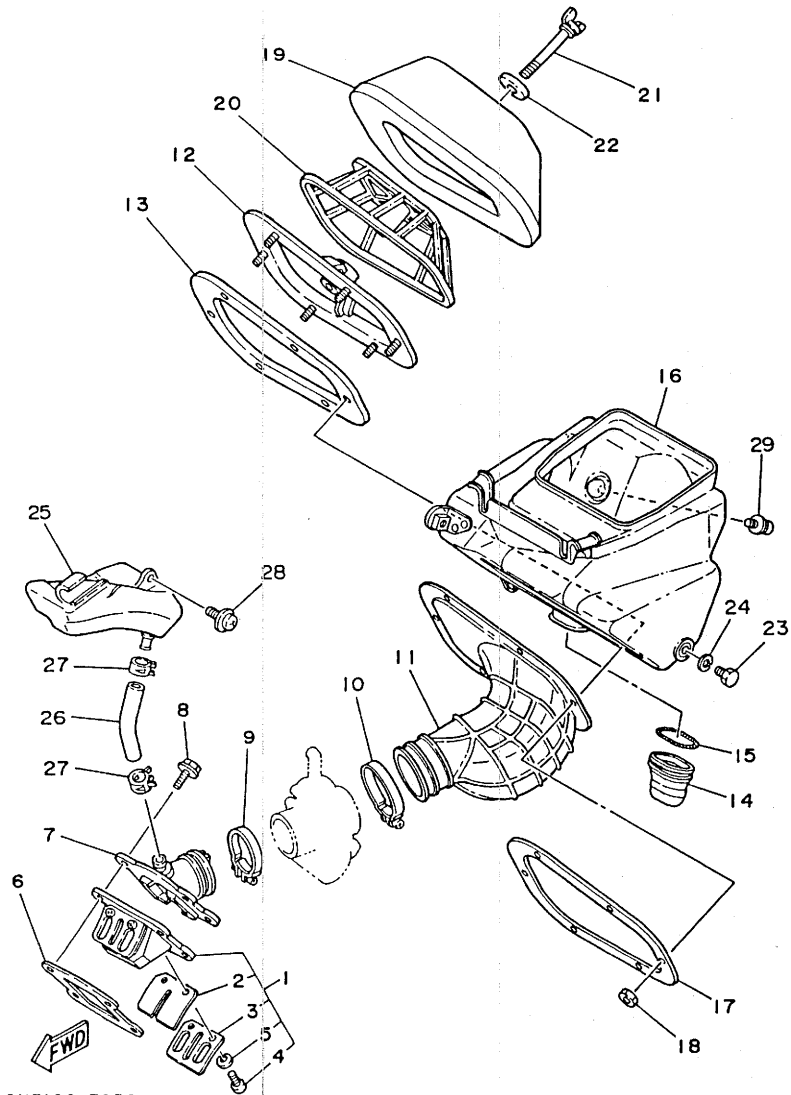

2HF100-7050

B7

FIG. 6 CARBURETOR

REF. NO.	PART NO.	DESCRIPTION	Q'TY	REMARKS
1	1LR-14101-00	CARBURETOR ASSY 1	1	
2	304-14184-00	.GASKET, float chamber	1	
3	260-14142-35	.JET, pilot (# 35)	1	STD
	260-14142-30	.JET, pilot (# 30)	1	AP
	260-14142-40	.JET, pilot (# 40)	1	AP
4	23L-14107-25	.NEEDLE VALVE SET	1	
5	127-14186-00	.PIN, float	1	
6	58T-1490J-00	.NEEDLE SET	1	
7	93210-18288	.O-RING	1	
8	3R1-14115-00	.PLUG, screw	1	
9	3R1-14141-52	.NOZZLE, main	1	STD
	3R1-14141-50	.NOZZLE, main	1	AP
	3R1-14141-54	.NOZZLE, main	1	AP
10	137-14143-56-A0	.JET, main (#280)	1	STD
	137-14143-54-A1	.JET, main (#270)	1	AP
	137-14143-58-A1	.JET, main (#290)	1	AP
	137-14143-60-A0	.JET, main (#300)	1	AP
11	314-14185-00	.FLOAT	1	
12	31J-14103-00	.THROTTLE SCREW SET	1	
13	53V-14196-00	.PIPE	3	
14	98511-04016	.SCREW, pan head	4	
15	92902-04100	.WASHER, spring	4	
16	22W-14106-00	.CABLE ADJUST SCREW SET	1	
17	3X3-14169-00	.CAP	1	
18	39K-14153-00	.WASHER, main jet	1	
19	2X6-14112-30	.VALVE, throttle 1	1	STD
	2X6-14112-25	.VALVE, throttle 1	1	AP
	2X6-14112-35	.VALVE, throttle 1	1	AP

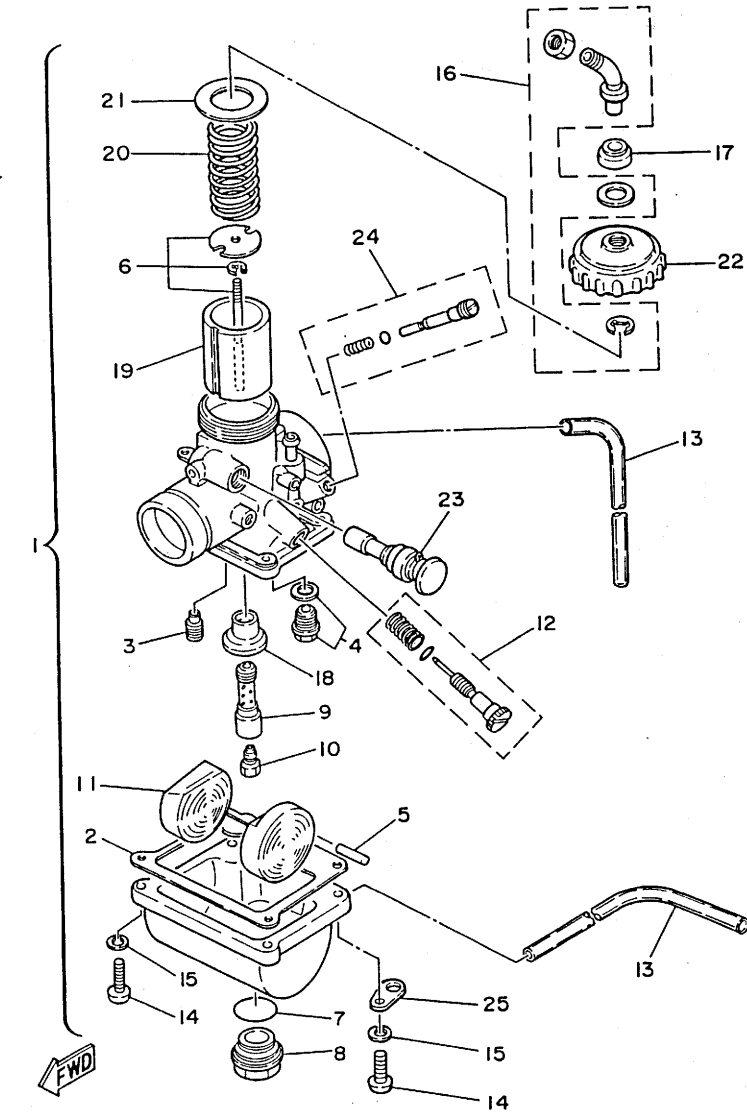

3ML2300-0060

B8

FIG. 7 EXHAUST

REF. NO.	PART NO.	DESCRIPTION	Q'TY	REMARKS
1	2HF-14610-01	EXHAUST PIPE ASSY 1	1	
2	39K-14718-00	PROTECTOR, muffler 1	1	
3	98906-06008	SCREW, bind	2	
4	90202-06010	WASHER, plate	2	
5	93210-40745	O-RING	1	
6	90507-20030	SPRING, tension	2	
7	565-14771-00	STAY, muffler 1	1	
8	97313-06016	BOLT	2	
9	92990-06100	WASHER, spring	2	
10	92901-06600	WASHER, plate	2	
11	1LR-14753-00	SILENCER, exhaust	1	UR FOR U.S.A.
	3ML-14753-00	SILENCER, exhaust	1	UR FOR CANADA, NEWZEALAND, S.AFRICA

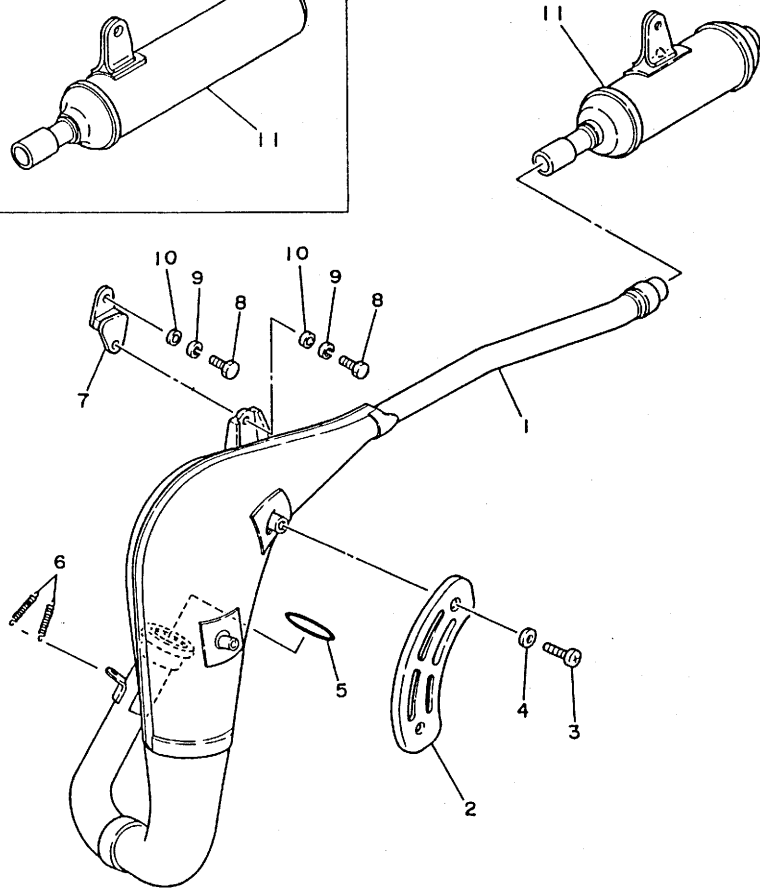
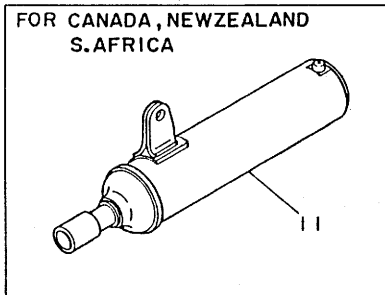

3MK3100-1070

B10

FIG. 8 CRANKCASE

REF. NO.	PART NO.	DESCRIPTION	Q'TY	REMARKS
1	2VE-15111-00	CRANKCASE 1	1	
2	98503-06045	SCREW, pan head	6	
3	98501-06035	SCREW, pan head	3	
4	353-13115-01	CONNECTOR, suction pipe	1	
5	90445-08376	HOSE	1	
6	99510-12016	PIN, dowel	2	
7	2VE-15121-00	CRANKCASE 2	1	
8	90338-07011	PLUG	1	
9	5X2-15113-01	PLATE	1	
10	98501-06012	SCREW, pan head	1	
11	90340-12059	PLUG, straight screw	1	
12	90430-12038	GASKET	1	

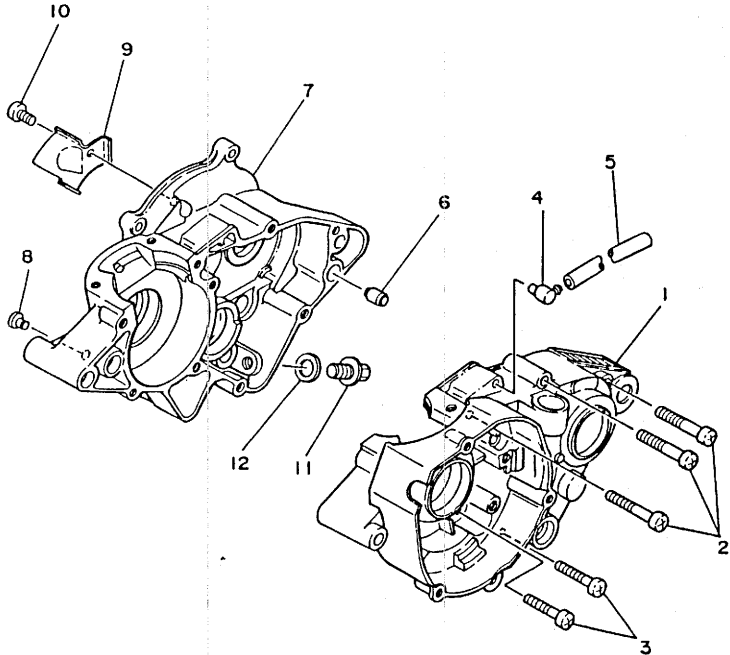

22W100-3090

B11

FIG. 9 CRANKCASE COVER 1

REF. NO.	PART NO.	DESCRIPTION	Q'TY	REMARKS
1	2VE-15411-00	COVER, crankcase 1	1	
2	22W-15451-01	GASKET, crankcase cover 1	1	
3	92516-06030	SCREW, pan head	3	
4	92906-06600	WASHER, plate	3	
5	2VE-15421-00	COVER, crankcase 2	1	
6	5X2-15462-00	GASKET, crankcase cover 3	1	
7	99530-10014	PIN, dowel	2	
8	92506-06025	SCREW, pan head	6	
9	98506-06040	SCREW, pan head	1	
10	4J2-15363-00	PLUG, oil	1	
11	93210-14104	O-RING	1	
12	98506-06008	SCREW, pan head	1	
13	90430-06016	GASKET	1	

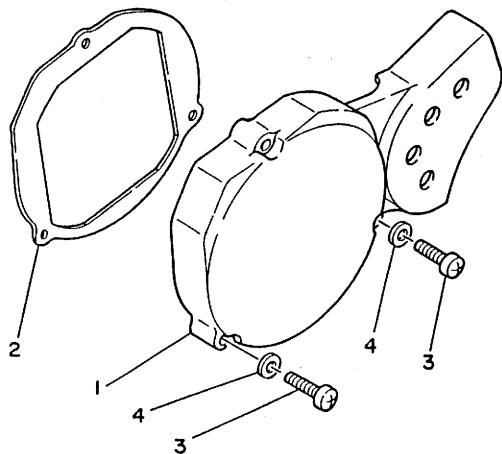
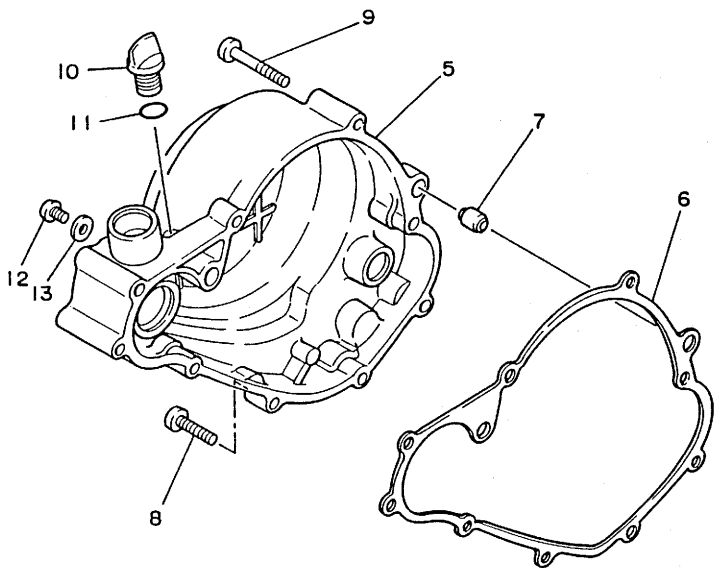

58T100-5090

B12

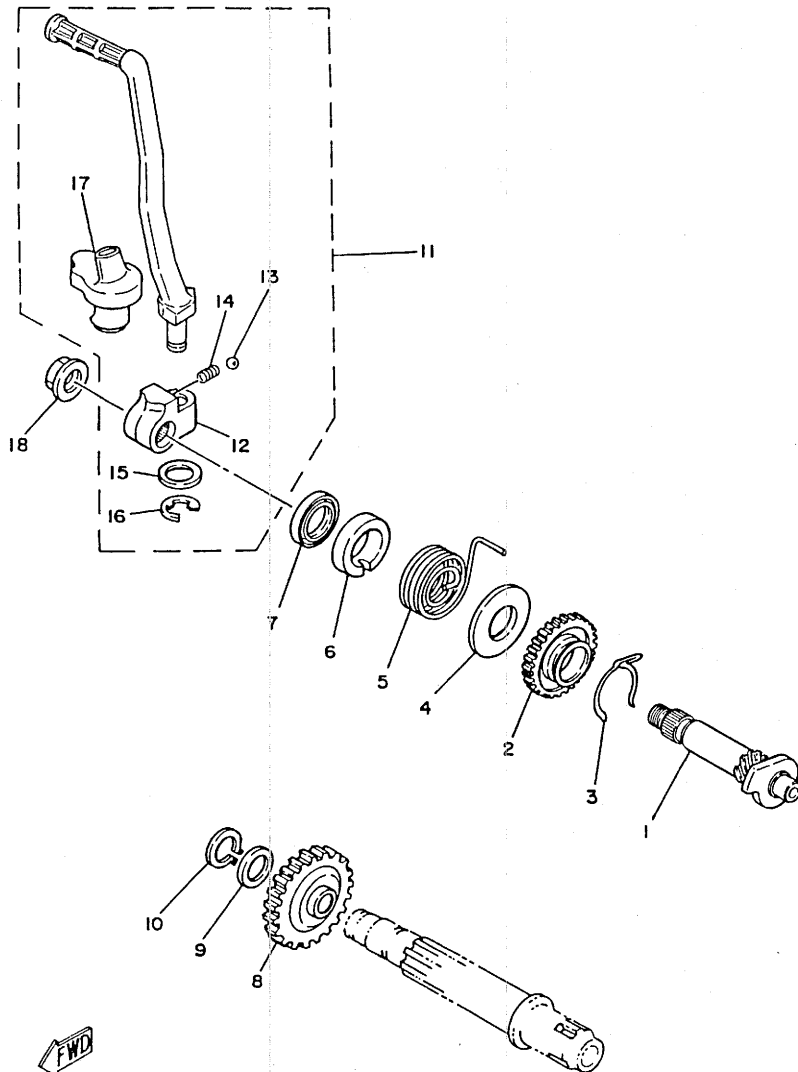

22W100-3110

FIG. 10 STARTER

REF. NO.	PART NO.	DESCRIPTION	Q'TY	REMARKS
1	22W-15660-00	KICK AXLE ASSY	1	
2	4V0-15641-00	GEAR, kick (24T)	1	
3	90468-26046	CLIP	1	
4	90201-154A1	WASHER, plate	1	
5	90508-26464	SPRING, torsion	1	
6	4V0-15664-00	GUIDE, spring	1	
7	93109-15001	OIL SEAL	1	
8	4V0-15651-00	GEAR, sprocket idle (25T)	1	
9	90201-12M34	WASHER, plate	1	
10	99009-12400	CIRCLIP	1	
11	22W-15620-00	KICK CRANK ASSY	1	
12	4V0-15621-00	.BOSS, kick crank	1	
13	93507-32031	.BALL	1	
14	90501-12081	.SPRING, compression	1	
15	90201-12631	.WASHER, plate	1	
16	93430-08007	.CIRCLIP	1	
17	4V0-15618-00	.COVER, kick lever	1	
18	95702-10500	NUT, flange	1	

B13

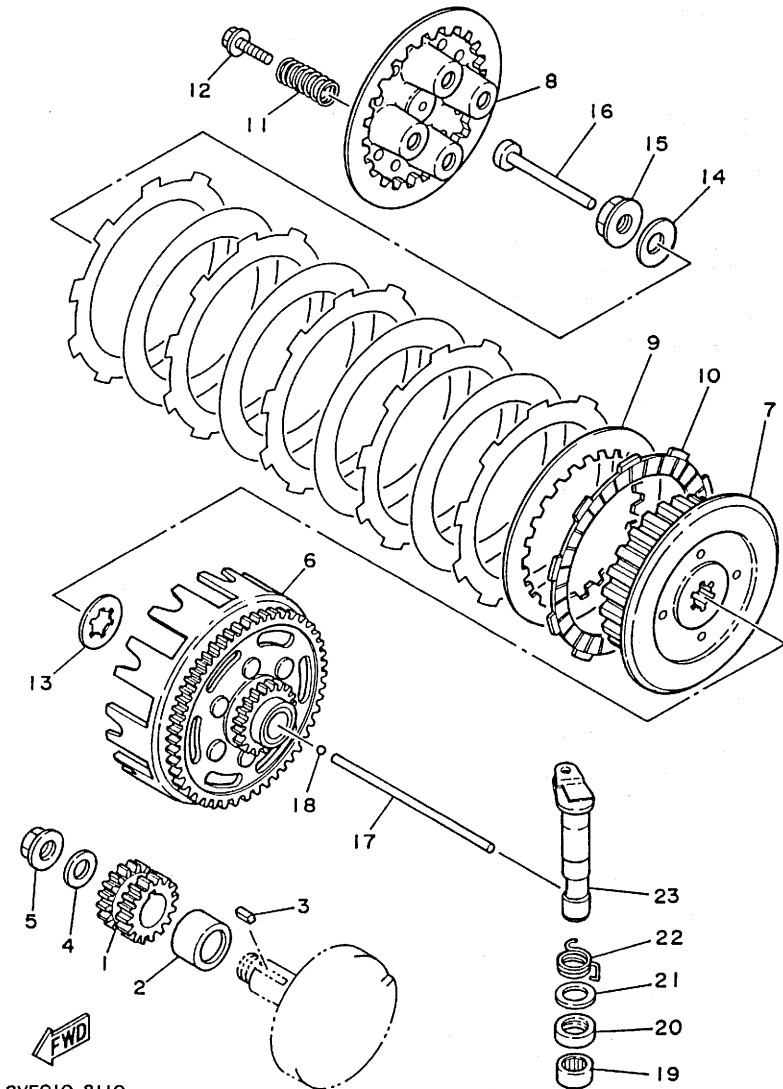
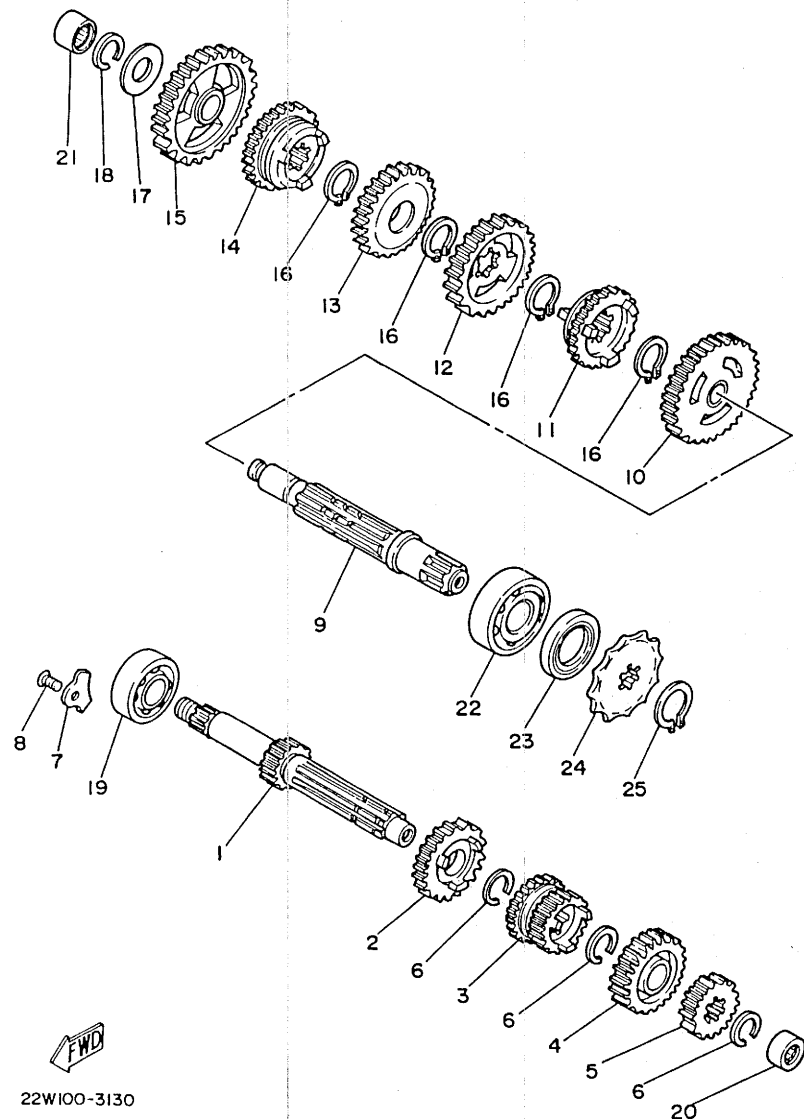

FIG. 11 CLUTCH

REF. NO.	PART NO.	DESCRIPTION	Q'TY	REMARKS
1	1LR-16111-00	GEAR, primary drive	1	
2	90387-202F0	COLLAR	1	
3	90282-05001	KEY, straight	1	
4	90208-12015	WASHER, conical spring	1	
5	90179-12335	NUT	1	
6	1LR-16150-00	PRIMARY DRIVEN GEAR COMP.	1	
7	1LR-16371-00	BOSS, clutch	1	
8	1LR-16351-00	PLATE, pressure 1	1	
9	257-16324-00	PLATE, clutch 1	5	
10	21V-16321-00	PLATE, friction	6	
11	90501-204A0	SPRING, compression	4	
12	90159-05011	SCREW, with washer	4	
13	4V0-16154-00	PLATE, thrust 1	1	
14	90208-12015	WASHER, conical spring	1	
15	90179-12244	NUT	1	
16	137-16356-00	ROD, push 1	1	
17	2X3-16357-00	ROD, push 2	1	
18	93503-16010	BALL	1	
19	93315-21429	BEARING, cylindrical	1	
20	93109-14021	OIL SEAL	1	
21	90201-14411	WASHER, plate	1	
22	90508-18463	SPRING, torsion	1	
23	58T-16382-00	AXLE, push lever	1	



22W100-3130

FIG. 12 TRANSMISSION

REF. NO.	PART NO.	DESCRIPTION	Q'TY	REMARKS
1	2VE-17411-00	AXLE, main	1	
2	2VE-17151-00	GEAR, 5th pinion (22T)	1	
3	2VE-17131-00	GEAR, 3rd pinion (16T/19T)	1	
4	2VE-17161-00	GEAR, 6th pinion (23T)	1	
5	2VE-17121-00	GEAR, 2nd pinion (16T)	1	
6	93440-17064	CIRCLIP	3	
7	3AK-15383-01	PLATE, bearing cover	2	
8	92701-06012	SCREW, flat head	2	
9	22W-17421-00	AXLE, drive	1	
10	39K-17221-00	GEAR, 2nd wheel (33T)	1	
11	39K-17261-01	GEAR, 6th wheel (26T)	1	
12	4V0-17231-00	GEAR, 3rd wheel (31T)	1	
13	39K-17241-00	GEAR, 4th wheel (22T)	1	
14	39K-17251-01	GEAR, 5th wheel (27T)	1	
15	4V0-17211-00	GEAR, 1st wheel (36T)	1	
16	93410-20038	CIRCLIP	4	
17	164-17427-00-06	SHIM 1 (0.6T)	1	
18	93440-15012	CIRCLIP	1	
19	93306-20333	BEARING	1	
20	93317-11245	BEARING, cylindrical	1	
21	93315-31502	BEARING, cylindrical	1	
22	93306-20401	BEARING (B6204)	1	
23	93102-20143	OIL SEAL	1	
24	93822-14037	SPROCKET, drive 14T (1741746140)	1	STD
	93822-12012	SPROCKET, drive 12T (1741746120)	1	AP
	93822-13024	SPROCKET, drive 13T (1741746130)	1	AP
	93822-15065	SPROCKET, drive 15T (1741746150)	1	AP
25	99009-18400	CIRCLIP	1	

B15

FIG. 13 SHIFT CAM. FORK

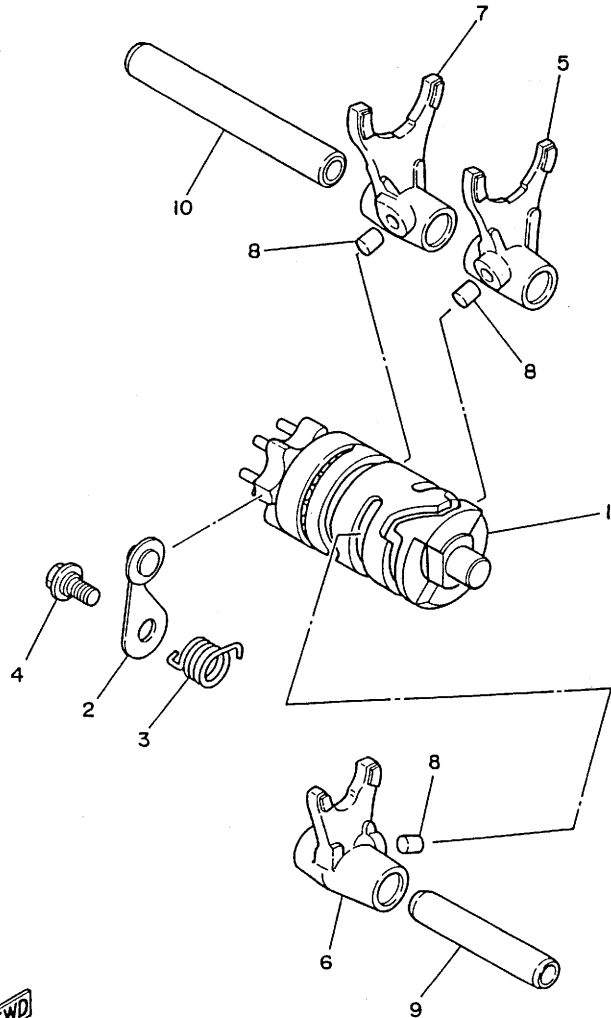

REF. NO.	PART NO.	DESCRIPTION	Q'TY	REMARKS
1	22W-18540-00	SHIFT CAM ASSY	1	
2	22W-18140-00	STOPPER LEVER ASSY	1	
3	90508-26561	SPRING, torsion	1	
4	90109-063F7	BOLT	1	
5	4V0-18511-00	FORK, shift 1	1	
6	39K-18512-00	FORK, shift 2	1	
7	4V0-18513-00	FORK, shift 3	1	
8	90250-06013	PIN, straight	3	
9	5X5-18531-01	BAR, shift fork guide 1	1	
10	5X5-18535-01	BAR, shift fork guide 2	1	



22W100-3140

C2

FIG. 14 SHIFT SHAFT

REF. NO.	PART NO.	DESCRIPTION	Q'TY	REMARKS
1	22W-18101-00	SHIFT SHAFT ASSY	1	
2	99006-10600	CIRCLIP	1	
3	90508-32642	SPRING, torsion	1	
4	93608-30152	PIN, dowel	1	
5	93109-12012	OIL SEAL	1	
6	2HF-18110-00	SHIFT PEDAL ASSY	1	
7	97011-06020	BOLT	1	

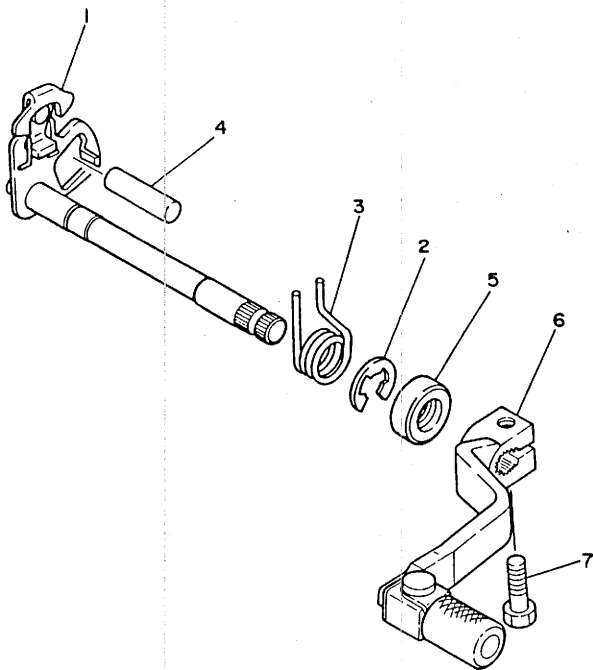

2HF100-7140

C3

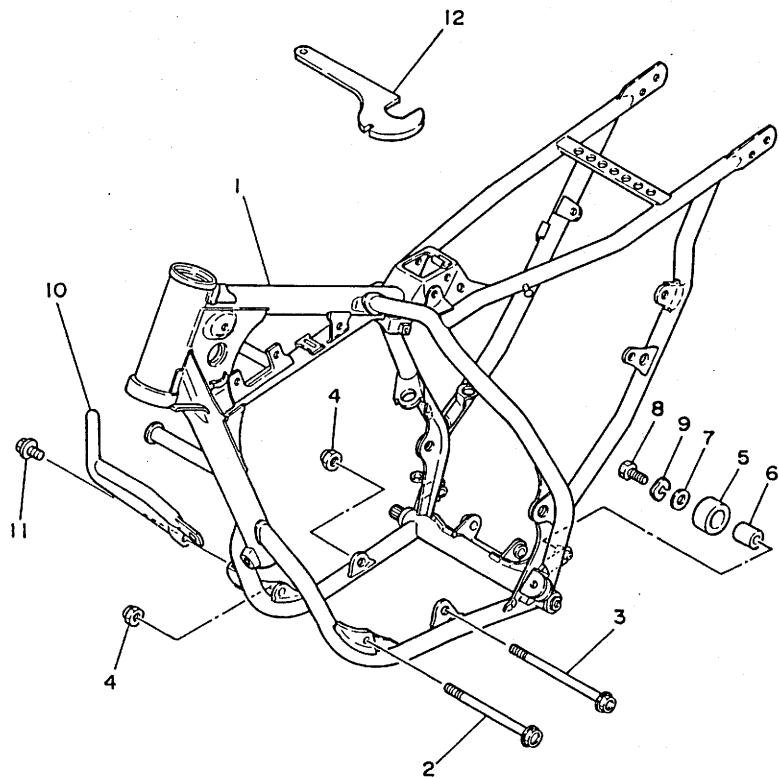

FIG. 15 FRAME

REF. NO.	PART NO.	DESCRIPTION	Q'TY	REMARKS
1	2HF-21110-00-UJ	FRAME COMP.	1	RADICAL WHITE
2	91011-08125	BOLT, flange	1	
3	91011-08135	BOLT, flange	1	
4	95601-08200	NUT, self-locking	2	
5	30X-22178-00	TENSIONER	1	
6	4V4-22184-00	BUSH	1	
7	90201-067A0	WASHER, plate	1	
8	97313-06016	BOLT	1	
9	92901-06700	WASHER, wave	1	
10	1LR-2174F-00	GUARD, radiator	1	
11	95023-08012	BOLT, flange	2	
12	10V-28135-00	SPANNER, special	1	



2HF100-7150

C4

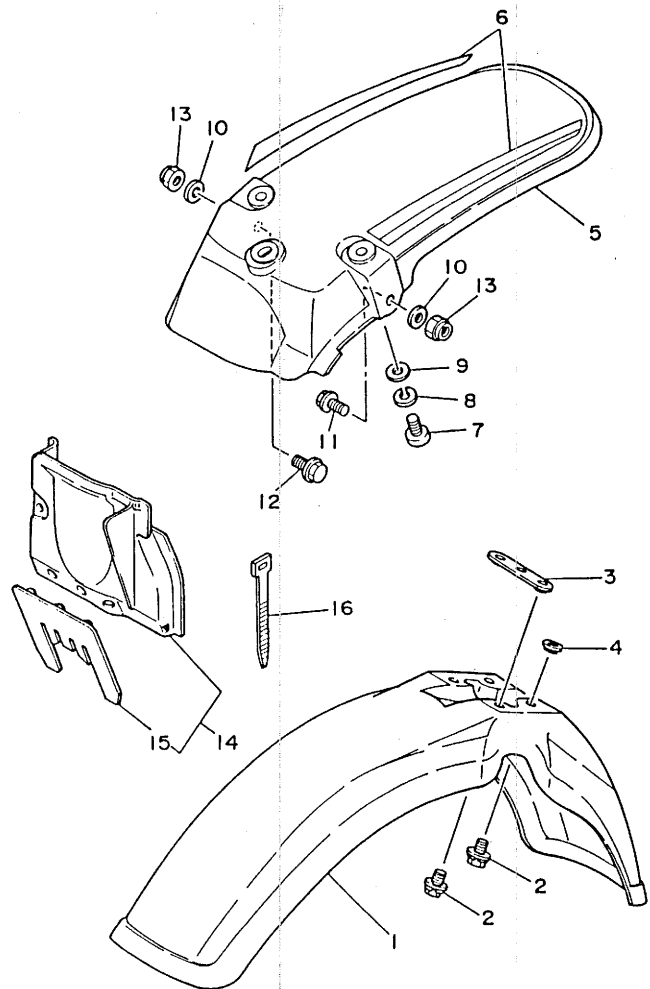

3MK3100-1160

FIG. 16 FENDER

REF. NO.	PART NO.	DESCRIPTION	Q'TY	REMARKS
1	3MK-21511-00	FENDER, front	1	PURPLISH WHITE SOLID 1
2	90119-06063	BOLT, with washer	4	
3	2VE-21523-00	PLATE 1	1	
4	90209-06187	WASHER	2	
5	3MK-21611-00	FENDER, rear	1	PURPLISH WHITE SOLID 1
6	3MK-2165A-00	GRAPHIC SET, rear fender	1	
7	98502-06016	SCREW, pan head	3	
8	92990-06100	WASHER, spring	3	
9	90201-065F3	WASHER, plate	3	
10	90201-08730	WASHER, plate	2	
11	91001-08025	BOLT, flange	1	
12	91001-08020	BOLT, flange	1	
13	95601-08200	NUT, self-locking	2	
14	39K-21620-01	MUD GUARD COMP.	1	
15	4V0-21621-00	.FLAP	1	
16	437-83936-01	BAND, switch cord	1	

FIG. 17 SIDE COVER

REF. NO.	PART NO.	DESCRIPTION	Q'TY	REMARKS
1	3MK-21711-00	COVER, side 1	1	PURPLISH WHITE SOLID 1
2	3MK-2173E-00	GRAPHIC 1	1	
3	22W-24181-00	DAMPER, locating 1	2	
4	92501-06014	SCREW, pan head	2	
5	92990-06100	WASHER, spring	2	
6	90201-06571	WASHER, plate	2	
7	3MK-21721-00-98	COVER, side 2	1	LOW GLOSS BLACK
8	2HF-14452-00	SEAL	1	
9	3MK-2173F-00	GRAPHIC 2	1	
10	92501-06014	SCREW, pan head	1	
11	92990-06100	WASHER, spring	1	
12	90201-06571	WASHER, plate	1	
13	90159-06032	SCREW, with washer	2	
14	98903-06010	SCREW, bind	1	
15	3MK-21741-00	COVER, side 4	1	PURPLISH WHITE SOLID 1
16	3MK-24248-00	GRAPHIC, fuel tank 5	1	
17	3MK-24246-00	GRAPHIC, fuel tank 3	1	
18	22W-21791-00	NUT	2	
19	90159-05101	SCREW, with washer	2	
20	1LR-2172A-00	PANEL 1	1	
21	90480-12053	GROMMET	1	
22	90159-06013	SCREW, with washer	1	

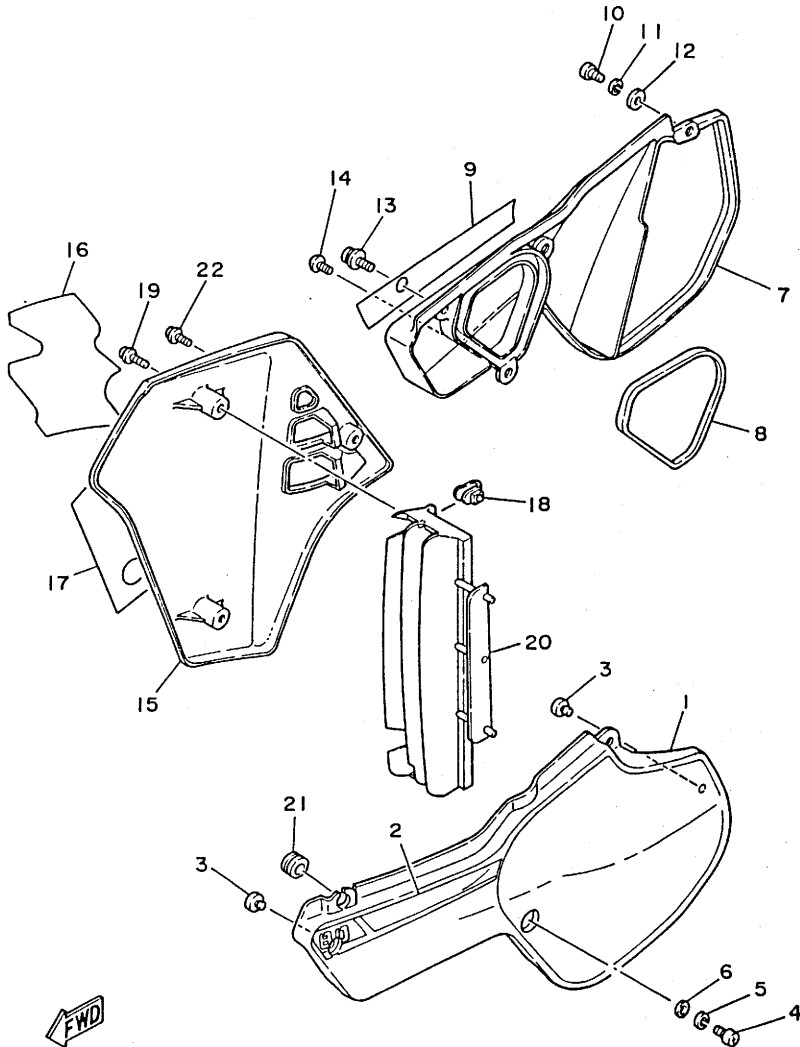

3MK3100-1170

C6

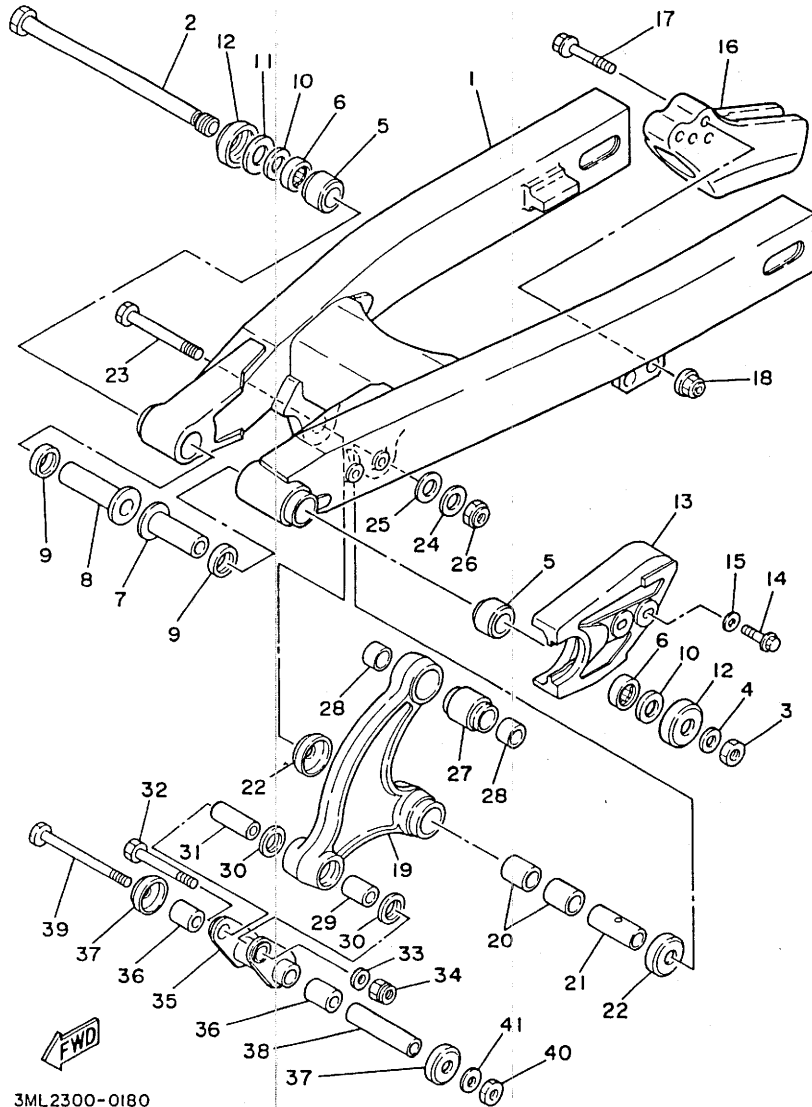

3ML2300-0180

FIG. 18 REAR ARM

REF. NO.	PART NO.	DESCRIPTION	Q'TY	REMARKS
1	2VE-22110-00	REAR ARM COMP.	1	
2	4V1-22141-00	SHAFT, pivot	1	
3	90185-12119	NUT, self-locking	1	
4	90201-124G9	WASHER, plate	1	
5	90385-17042	BUSH	2	
6	93317-21746	BEARING, cylindrical	2	
7	90387-127J8	COLLAR	1	
8	90387-127J7	COLLAR	1	
9	93109-17048	OIL SEAL (SDO 17-24-4)	2	
10	90201-191J4	WASHER, plate	2	
11	401-22127-00	SHIM	1	
12	401-22128-01	SEAL, guard	2	
13	1LR-22151-00	SEAL, guard	1	
14	95026-06025	BOLT, flange	2	
15	90201-06067	WASHER, plate	2	
16	39K-22199-00	SUPPORT, chain	1	
17	91021-08045	BOLT, flange	2	
18	95601-08200	NUT, self-locking	2	
19	39K-2217A-00	ARM, relay	1	
20	90384-18190	BUSH, bimetal formed	2	
21	90380-12094	BUSH, solid	1	
22	5X6-22129-00	COVER, thrust 2	2	
23	90109-100E4	BOLT	1	
24	90201-100E9	WASHER, plate	1	
25	90201-120A5	WASHER, plate	1	
26	90185-10120	NUT, self-locking	1	
27	22W-22124-00	BUSH 2	1	
28	90380-16109	BUSH, solid	2	

C7

FIG. 28 REAR ARM

REF. NO.	PART NO.	DESCRIPTION	Q'TY	REMARKS
29	90383-16023	BUSH, formed	1	
30	93109-16035	OIL SEAL	2	
31	90387-106G0	COLLAR	1	
32	90109-10689	BOLT	1	
33	92990-10600	WASHER, plate	1	
34	90185-10120	NUT, self-locking	1	
35	22W-2217F-00	ROD, connecting 1	1	
36	90383-16023	BUSH, formed	2	
37	22W-22129-00	COVER, thrust 2	2	
38	90387-105G9	COLLAR	1	
39	90109-10688	BOLT	1	
40	90185-10120	NUT, self-locking	1	
41	92990-10600	WASHER, plate	1	

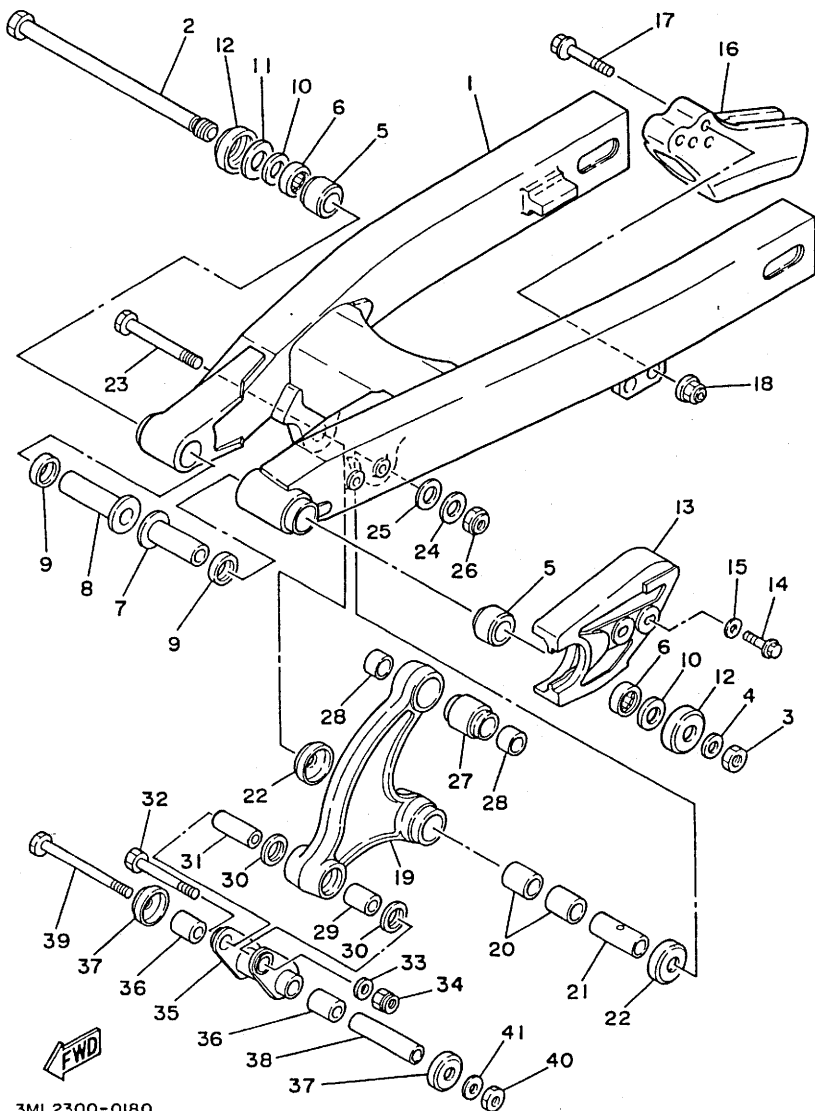

3ML2300-0180

FIG. 19 REAR SUSPENSION

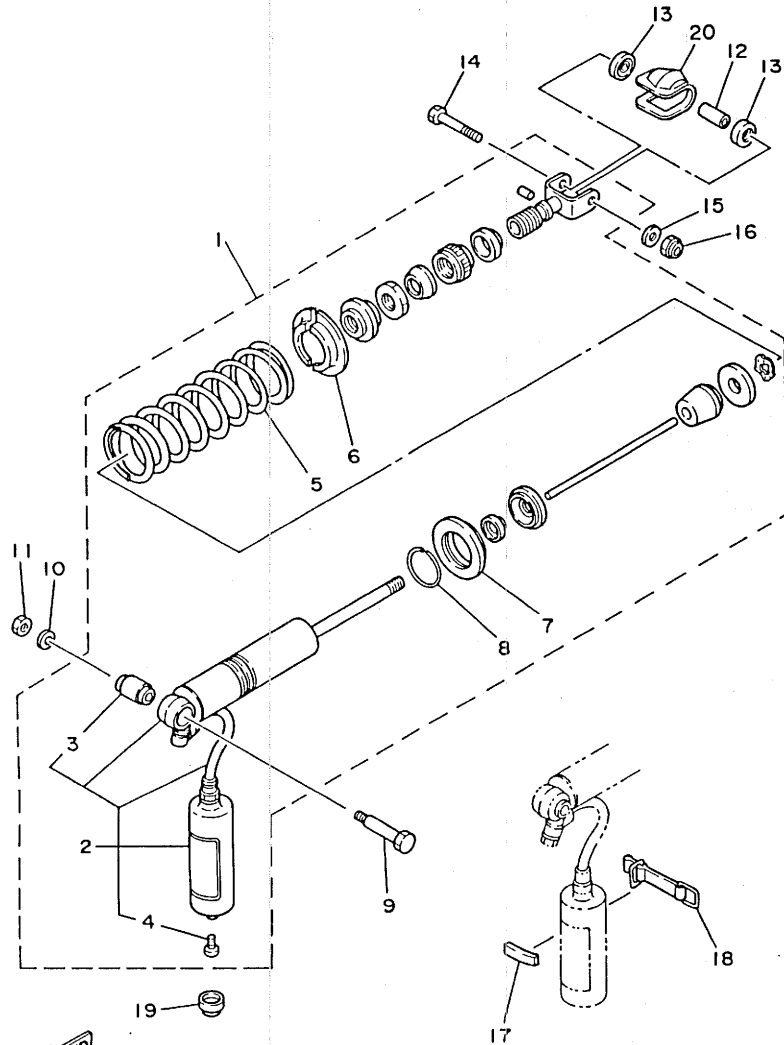

REF. NO.	PART NO.	DESCRIPTION	Q'TY	REMARKS
1	3MK-22210-00-PO	SHOCK ABSORBER ASSY, rear	1	UR
	3ML-22210-00-PO	SHOCK ABSORBER ASSY, rear	1	UR FOR CANADA
2	2HF-22201-00	.DAMPER SUB ASSY	1	
3	2X6-22216-00	..BUSH, rear shock absorber	1	
4	98501-04006	..SCREW, pan head	1	
5	2HF-22212-00-PO	.SPRING	1	VIVID MAGENTA SOLID
6	22W-22214-01	.GUIDE, spring 1	2	
7	22W-22223-00	.SEAT, spring lower	1	
8	93440-42101	.CIRCLIP	1	
9	90109-10729	BOLT	1	
10	92990-10600	WASHER, plate	1	
11	90185-10120	NUT, self-locking	1	
12	90387-10660	COLLAR	1	
13	22W-22129-00	COVER, thrust 2	2	
14	90109-10689	BOLT	1	
15	92990-10600	WASHER, plate	1	
16	90185-10120	NUT, self-locking	1	
17	24X-22261-00	DAMPER, sub tank	1	
18	24X-22262-00	HOLDER, sub tank	1	
19	90480-17359	GROMMET	1	
20	22W-22189-00	BOOT, rubber	1	

2VFO10-8190

C9

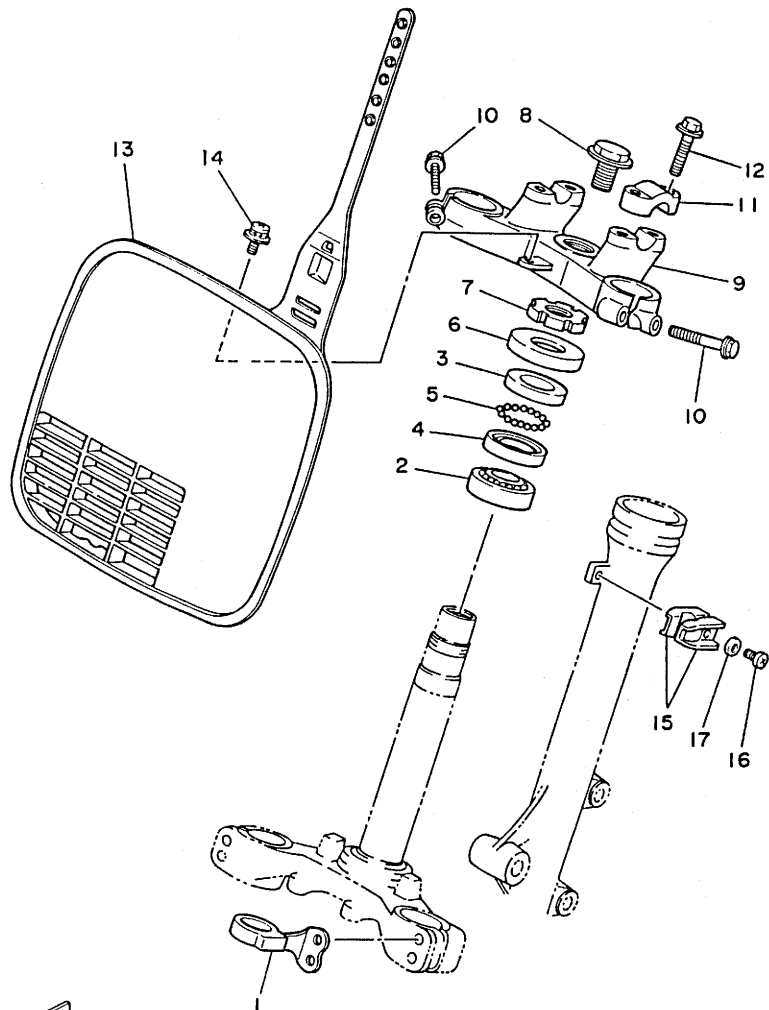

FIG. 20 STEERING

REF. NO.	PART NO.	DESCRIPTION	Q'TY	REMARKS
1	3R4-23389-00	GUIDE, cable	1	
2	93332-00059	BEARING	1	
3	122-23411-00	RACE, ball 1	1	
4	122-23412-00	RACE, ball 2	1	
5	93503-16010	BALL	22	
6	10V-23416-01	COVER, ball race 2	1	
7	90179-25033	NUT	1	
8	90105-14102	BOLT, washer based	1	
9	22W-23435-00-35	CROWN, handle	1	SILVER
10	91001-08035	BOLT, flange	2	
11	3SP-23441-00	HOLDER, handle upper	2	
12	91021-08030	BOLT, flange	4	
13	3MK-23485-00	PLATE, number	1	PURPLISH WHITE SOLID 1
14	90159-06060	SCREW, with washer	1	
15	90465-14242	CLAMP	2	
16	91311-06016	BOLT	2	
17	92901-06600	WASHER, plate	2	



3ML2300-0200

C10

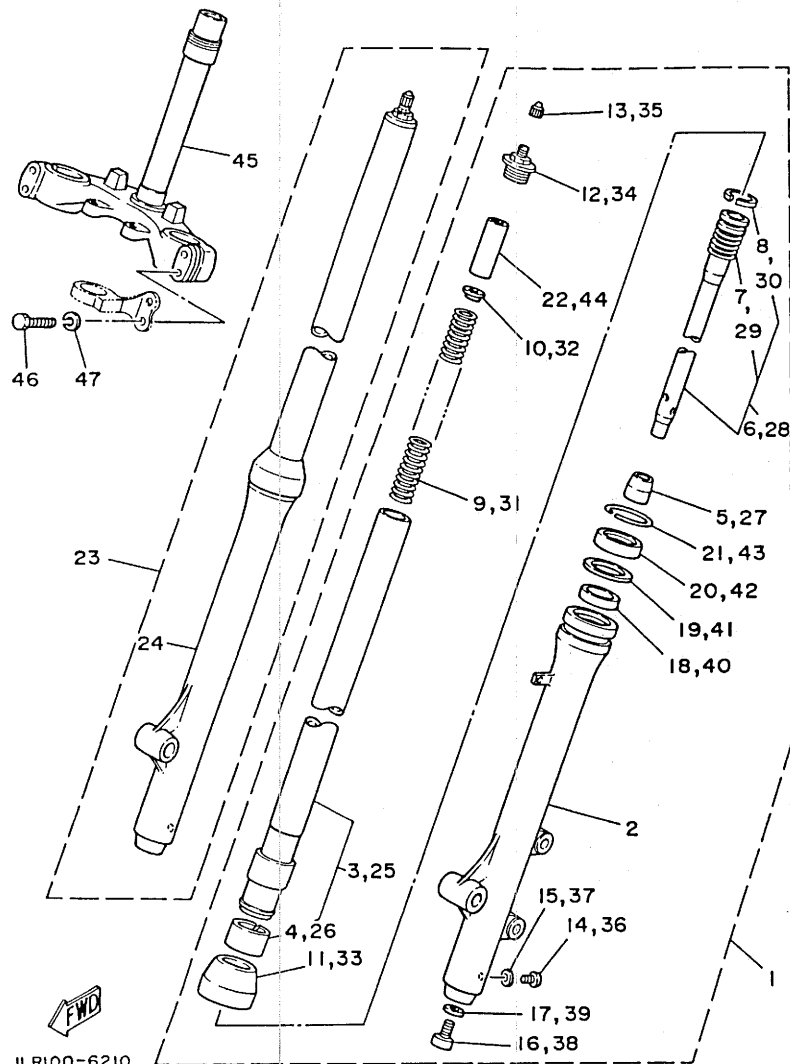

ILRI00-6210

FIG. 21 FRONT FORK

REF. NO.	PART NO.	DESCRIPTION	Q'TY	REMARKS
1	2HF-23102-LO	FRONT FORK ASSY (L.H)	1	
2	2HF-23126-LO-35	.TUBE, outer 1	1	SILVER
3	58T-23110-LO	.INNER TUBE COMP.1	1	
4	22W-2312K-00	..PISTON, front fork	1	
5	39K-23173-00	.SPINDLE, taper	1	
6	39K-23170-LO	.CYLINDER COMP., front fork	1	
7	509-23151-LO	..SPRING, rebound	1	
8	22W-23157-LO	..RING, piston	1	
9	39K-23141-00	.SPRING, front fork (K=0.23)	1	
10	583-23142-00	.SEAT, spring upper	1	
11	22W-23144-LO	.SEAL, dust	1	
12	58T-23111-LO	.BOLT, cap	2	
13	58T-23184-LO	.CAP, air valve	1	
14	4H7-23119-00	.PLUG, drain	1	
15	122-23129-00	.GASKET, drain plug	1	
16	278-23181-50	.BOLT, hexagon socket head	1	
17	509-23158-LO	.GASKET	1	
18	22W-23125-LO	.METAL, slide 1	1	
19	22W-23146-LO	.WASHER, oil seal	1	
20	22W-23145-LO	.OIL SEAL	1	
21	22W-23153-LO	.RING, snap	1	
22	58T-23118-LO	.SPACER	1	
23	2HF-23103-LO	FRONT FORK ASSY (R.H)	1	
24	2HF-23136-LO-35	.TUBE, outer 2	1	SILVER
25	58T-23110-LO	.INNER TUBE COMP.1	1	
26	22W-2312K-00	..PISTON, front fork	1	
27	39K-23173-00	.SPINDLE, taper	1	
28	39K-23170-LO	.CYLINDER COMP., front fork	1	

C11

FIG. 21 FRONT FORK

REF. NO.	PART NO.	DESCRIPTION	Q'TY	REMARKS
29	509-23151-L0	..SPRING, rebound	1	
30	22W-23157-L0	..RING, piston	1	
31	39K-23141-00	.SPRING, front fork (K=0.23)	1	
32	583-23142-00	.SEAT, spring upper	1	
33	22W-23144-L0	.SEAL, dust	1	
34	58T-23111-L0	.BOLT, cap	1	
35	58T-23184-L0	.CAP, air valve	1	
36	4H7-23119-00	.PLUG, drain	1	
37	122-23129-00	.GASKET, drain plug	1	
38	278-23181-50	.BOLT, hexagon socket head	1	
39	509-23158-L0	.GASKET	1	
40	22W-23125-L0	.METAL, slide 1	1	
41	22W-23146-L0	.WASHER, oil seal	1	
42	22W-23145-L0	.OIL SEAL	1	
43	22W-23153-L0	.RING, snap	1	
44	58T-23118-L0	.SPACER	1	
45	39K-23340-L0	UNDER BRACKET COMP.	1	
46	97313-08040	BOLT	4	
47	92990-08100	WASHER, spring	4	

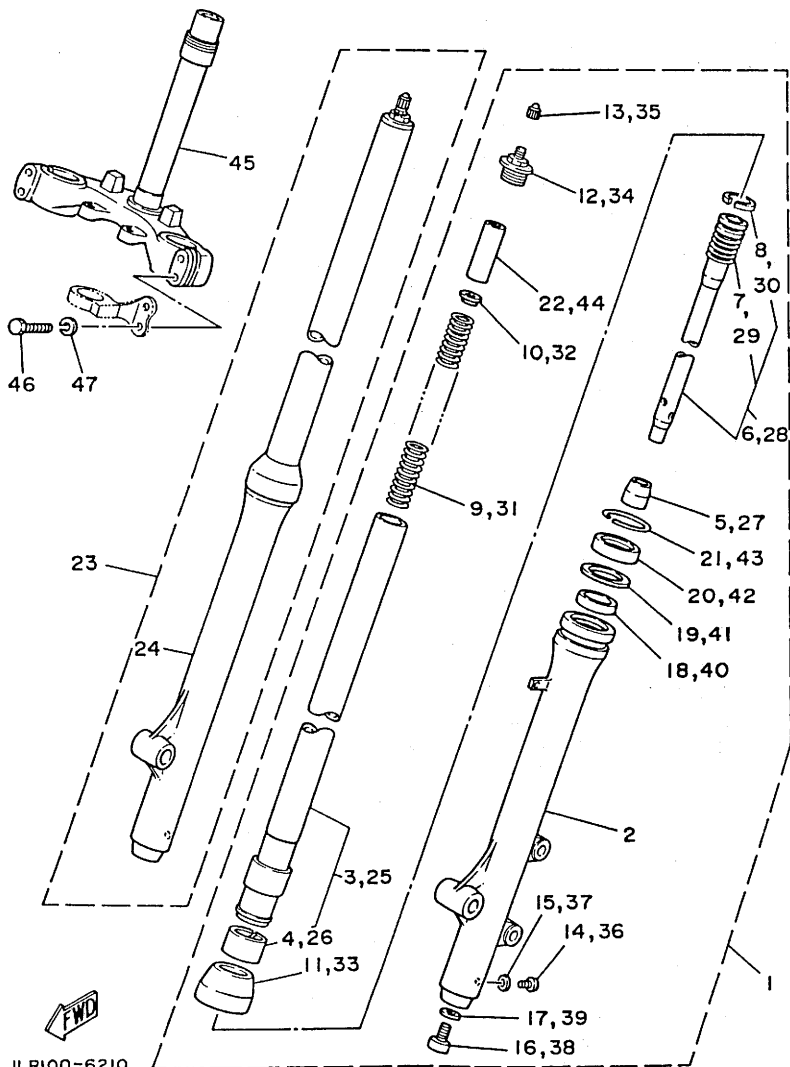

ILRI00-6210

FIG. 22 FUEL TANK

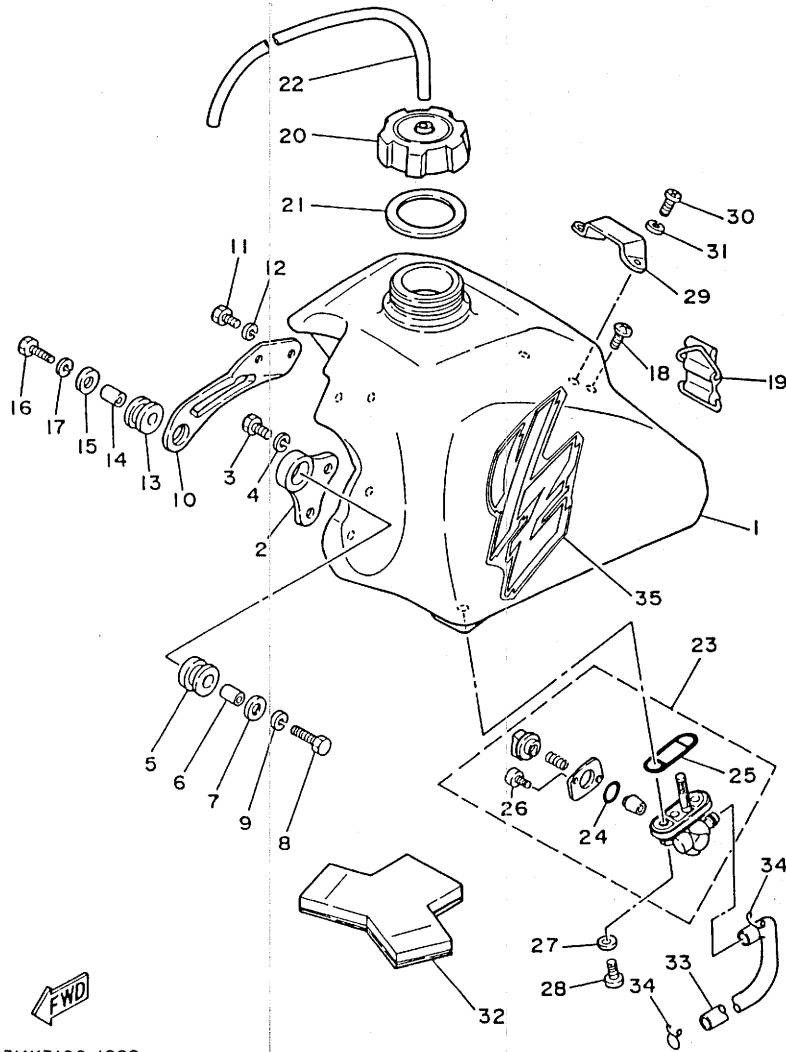

3MK3100-1220

REF. NO.	PART NO.	DESCRIPTION	Q'TY	REMARKS
1	3MK-24110-00	FUEL TANK COMP.	1	PURPLISH WHITE SOLID 1
2	1LR-24157-00	STAY, fuel tank 1	1	
3	97003-06012	BOLT	2	
4	92990-06100	WASHER, spring	2	
5	90480-18290	GROMMET	1	
6	90387-07598	COLLAR	1	
7	90201-06072	WASHER, plate	1	
8	97021-06030	BOLT	1	
9	92990-06100	WASHER, spring	1	
10	22W-24158-00	STAY, fuel tank 2	1	
11	97003-06012	BOLT	2	
12	92990-06100	WASHER, spring	2	
13	90480-18290	GROMMET	1	
14	90387-07598	COLLAR	1	
15	90201-06072	WASHER, plate	1	
16	97021-06030	BOLT	1	
17	92990-06100	WASHER, spring	1	
18	98980-06020	SCREW, bind	1	
19	59V-24173-00	BAND, tank fitting 1	1	
20	5X7-24611-01	BODY, cap	1	
21	5X7-24612-00	GASKET, cap	1	
22	90445-09304	HOSE	1	
23	2VE-24500-01	FUEL COCK ASSY 1	1	
24	4X8-24534-00	.SEAL, cock	1	
25	4X8-24512-00	.O-RING	1	
26	98503-03008	.SCREW, pan head	2	
27	90202-06010	WASHER, plate	2	
28	90149-06011	SCREW	2	

C13

FIG. 23 SEAT

REF. NO.	PART NO.	DESCRIPTION	Q'TY	REMARKS
1	3MK-24770-00	SEMI-DOUBLE SEAT ASSY	1	
2	3MK-24731-00	.COVER, seat	1	

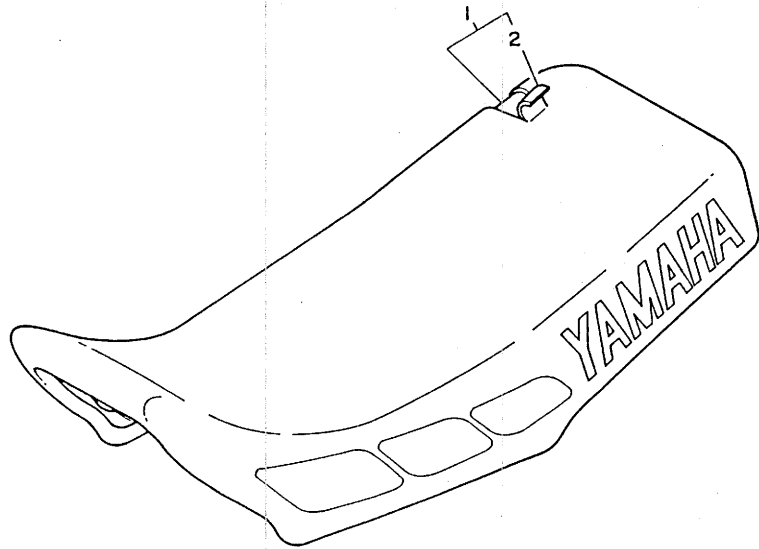

3ML2300-0230

C15

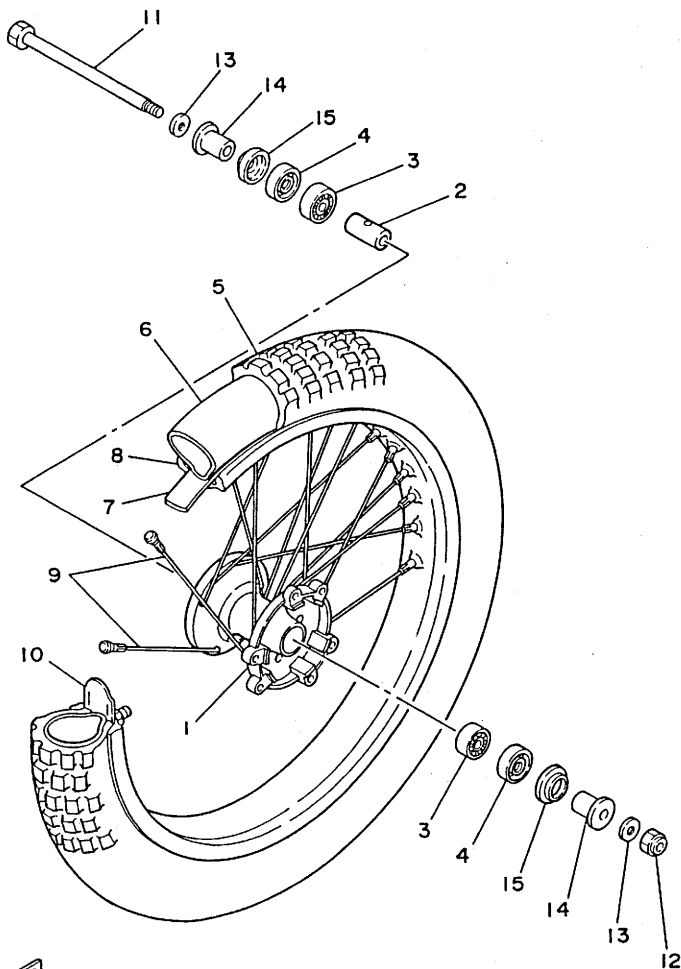

FIG. 24 FRONT WHEEL

REF. NO.	PART NO.	DESCRIPTION	Q'TY	REMARKS
1	1LR-25111-00-98	HUB, front	1	LOW GLOSS BLACK
2	90560-12257	SPACER	1	
3	93306-00105	BEARING (B6001)	2	
4	93106-18013	OIL SEAL	2	
5	94107-177R6	TIRE (70/100-17)	1	INOUE
6	94208-17255	TUBE (80/80-17)	1	INOUE
7	94332-17112	BAND, rim (3.25-17)	1	INOUE
8	94414-17428	RIM (1.40-17)	1	
9	1LR-25104-00	SPOKE SET, front	1	
10	1T1-25194-00	SPACER, bead	1	
11	22W-25181-01	AXLE, wheel	1	
12	90185-12046	NUT, self-locking	1	
13	90201-122A7	WASHER, plate	2	
14	90387-126F8	COLLAR	2	
15	462-25118-00	COVER, hub dust	2	



ILR100-6241

D2

FIG. 25 FRONT BRAKE CALIPER

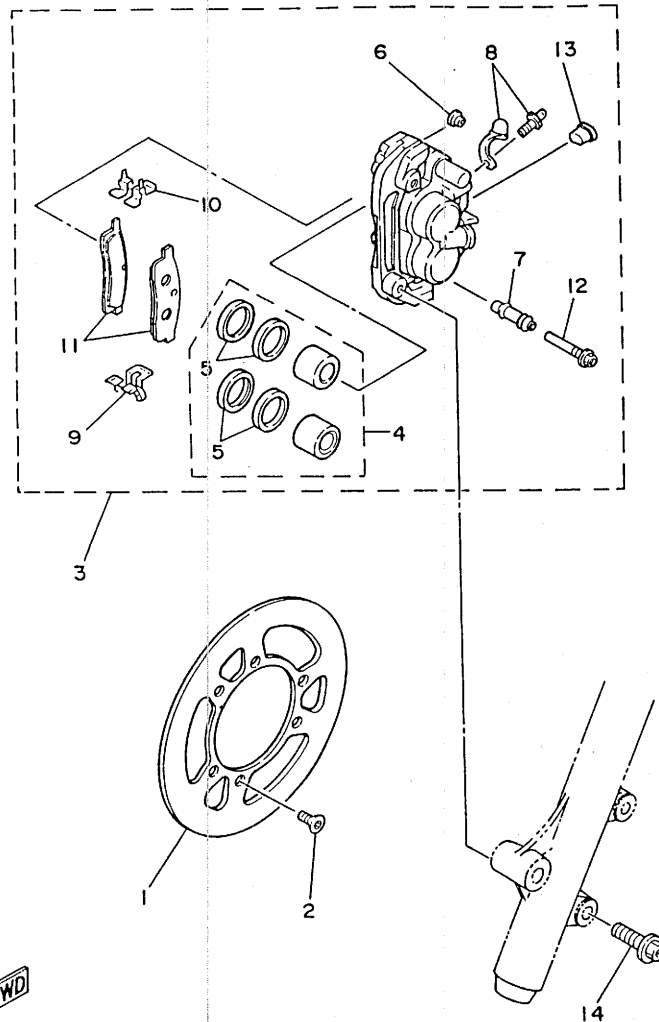

REF. NO.	PART NO.	DESCRIPTION	Q'TY	REMARKS
1	1LR-25831-00	DISC, brake (RIGHT)	1	
2	90149-06248	SCREW	6	
3	3MK-2580T-00	CALIPER ASSY (LEFT)	1	
4	1LR-W0057-00	.PISTON ASSY, caliper	1	
5	1LR-W0047-00	..CALIPER SEAL KIT	1	
6	5R2-25937-00	.BOOT 2	1	
7	56A-25937-00	.BOOT 2	1	
8	51L-W0048-00	.BREED SCREW KIT	1	
9	56A-25919-00	.SUPPORT, pad	1	
10	56A-25919-10	.SUPPORT, pad	1	
11	2HF-W0046-00	.BRAKE PAD KIT, rear	1	
12	56A-25926-00	.BOLT	1	
13	34X-25845-00	.CAP, indicator	1	
14	95811-08035	BOLT, flange	2	

FWD

2VF010-8250

D3

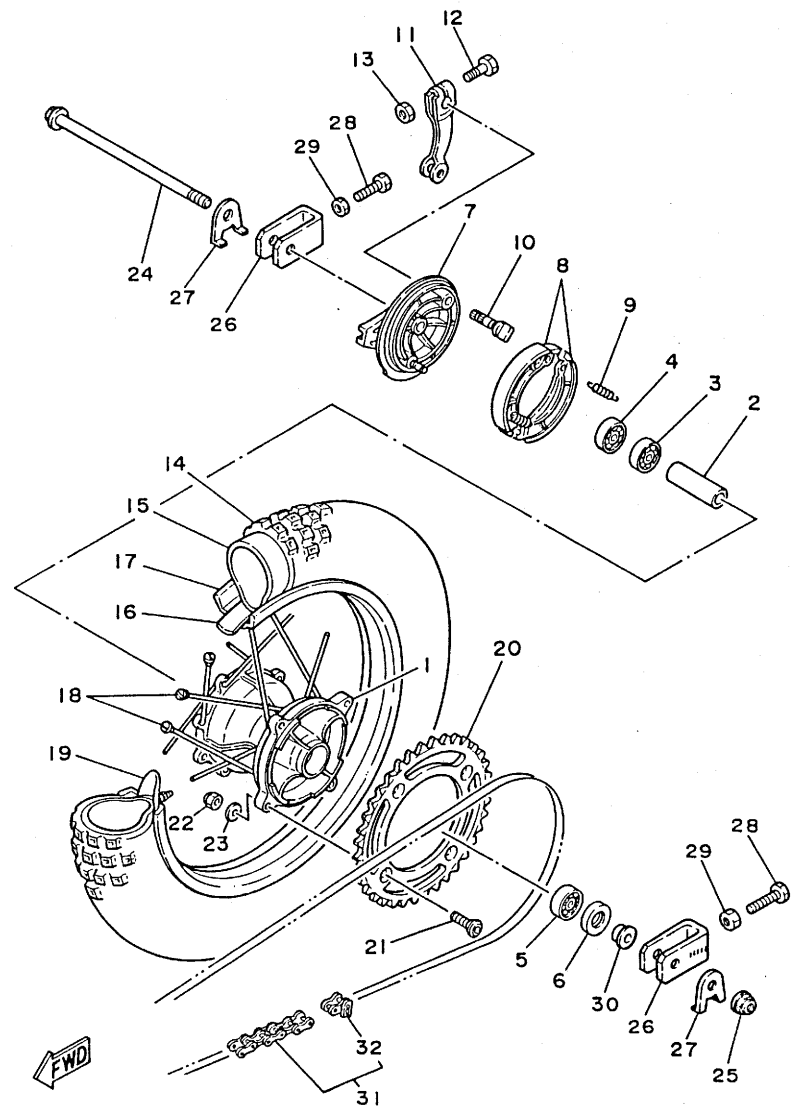

2HF100-7260

FIG. 26 REAR WHEEL

REF. NO.	PART NO.	DESCRIPTION	Q'TY	REMARKS
1	39K-25311-00-98	HUB, rear	1	LOW GLOSS BLACK
2	90560-12320	SPACER	1	
3	93306-00108	BEARING	1	
4	93306-00105	BEARING (B6001)	1	
5	93306-30101	BEARING (B6301)	1	
6	93106-20002	OIL SEAL	1	
7	39K-25321-00-98	PLATE, brake shoe	1	LOW GLOSS BLACK
8	39K-W2535-00	BRAKE SHOE SET	1	
9	90506-14081	SPRING, tension	2	
10	4N0-25151-00	CAMSHAFT	1	
11	3R0-25355-11	LEVER, camshaft	1	
12	90101-06278	BOLT	1	
13	95303-06600	NUT	1	
14	94109-147R7	TIRE (90/100-14)	1	INOUE
15	94232-14174	TUBE (3.25-14)	1	INOUE
16	94327-14076	BAND, rim (2.75-14)	1	INOUE
17	94416-14375	RIM (1.60-14)	1	
18	39K-25304-00	SPOKE SET, rear	1	
19	5X2-25394-00	SPACER, bead	1	
20	39K-25446-00	SPROCKET, driven (46T)	1	STD
	39K-25444-01	SPROCKET, driven (44T)	1	AP
	39K-25448-00	SPROCKET, driven (48T)	1	AP
	39K-25450-01	SPROCKET, driven (50T)	1	AP
21	90109-08706	BOLT	4	
22	95611-08100	NUT, u	4	
23	90201-081A6	WASHER, plate	4	
24	1LR-25381-01	AXLE, wheel	1	
25	95601-12200	NUT, self-locking	1	

D4

FIG. 26 REAR WHEEL

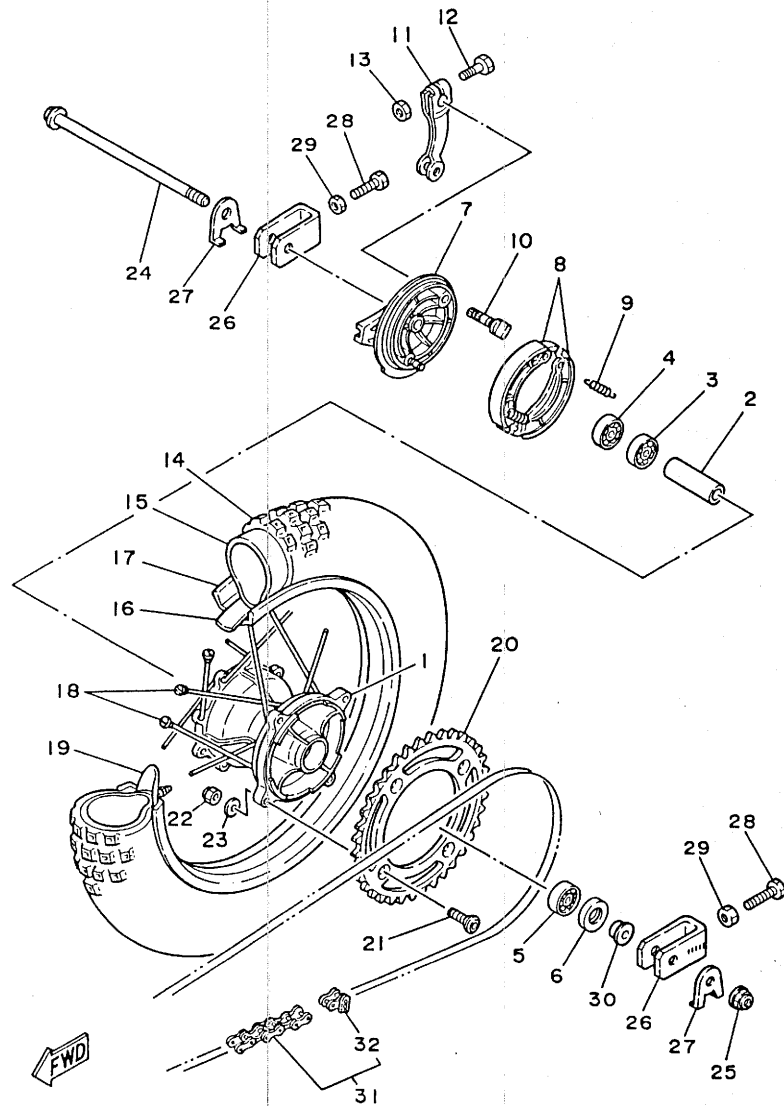

REF. NO.	PART NO.	DESCRIPTION	Q'TY	REMARKS
26	2HF-25388-00	PULLER, chain 1	2	
27	51L-2533A-00	PLATE, indicator	2	
28	90101-08699	BOLT	2	
29	95303-08700	NUT	2	
30	90387-126R2	COLLAR	1	
31	94580-24112	CHAIN, drive (DID428 112L)	1	
32	94680-24001	.JOINT, chain (DID 428)	1	

2HF100-7260

D5

FIG. 27 STEERING HANDLE. CABLE

REF. NO.	PART NO.	DESCRIPTION	Q'TY	REMARKS
1	2HF-26111-00-35	HANDLEBAR	1	SILVER
2	1LX-26242-01	GRIP (R.H)	1	
3	22W-26243-00	TUBE, throttle guide	1	
4	688-82535-00	GROMMET	1	
5	1LX-26241-01	GRIP (L.H)	1	
6	5X2-26281-00	CAP, grip upper	1	
7	322-26282-00	CAP, grip lower	1	
8	5X2-2628H-01	CAP, wire	1	
9	98706-04012	SCREW, flat head	2	
10	98506-05016	SCREW, pan head	2	
11	90387-22647	COLLAR	1	
12	22W-26311-00	CABLE, throttle 1	1	
13	39K-26335-01	CABLE, clutch	1	
14	382-26372-01	.COVER, handle lever 1	1	
15	90123-08013	BOLT	1	
16	90179-08148	NUT	1	

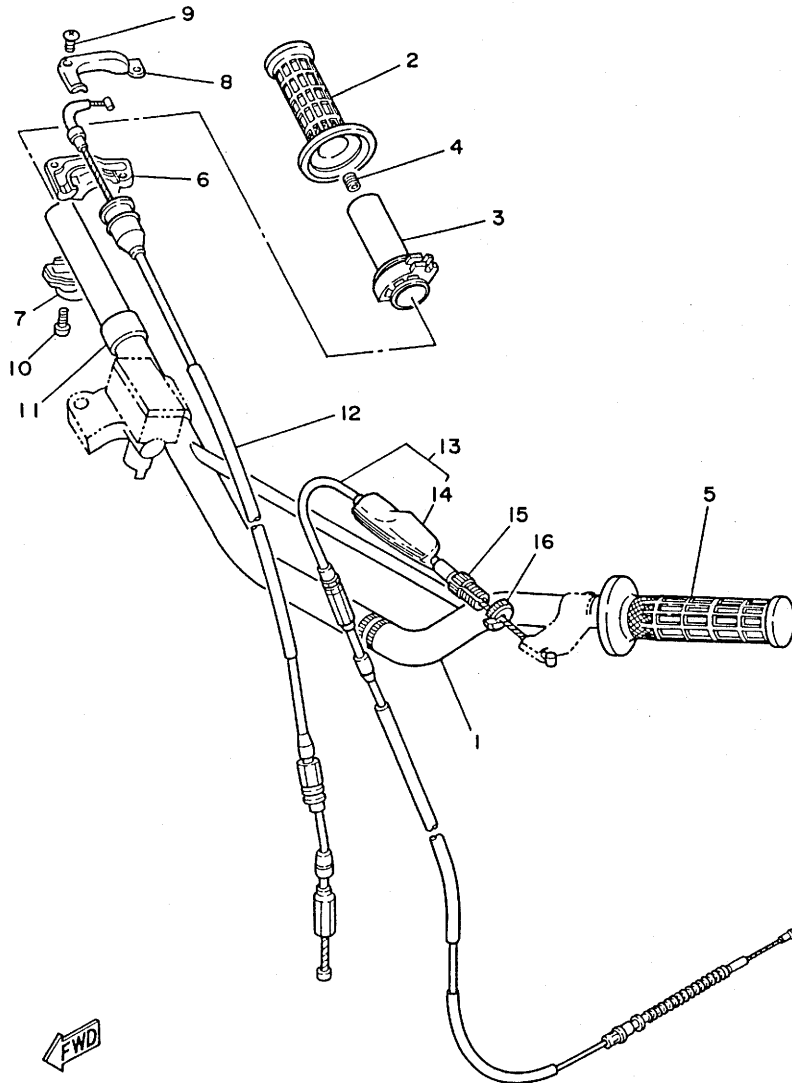

2HF100-7270

D6

FIG. 28 FRONT MASTER CYLINDER

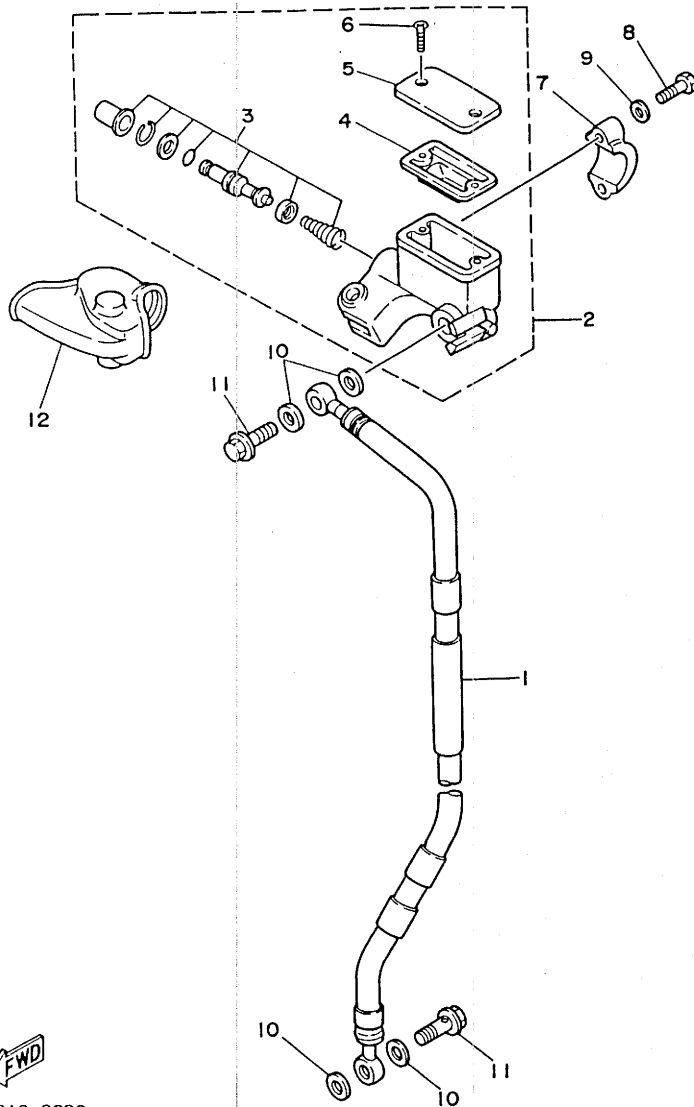

REF. NO.	PART NO.	DESCRIPTION	Q'TY	REMARKS
1	2HF-25872-00	HOSE, brake 1	1	
2	2VN-25870-00	MASTER CYLINDER SUB ASSY	1	
3	56A-W0041-00	.CYLINDER KIT, master	1	
4	56A-25854-00	.DIAPHRAGM, reservoir	1	
5	2VN-25852-00	.CAP, reservoir	1	
6	98706-04012	.SCREW, flat head	2	
7	56A-25867-00	BRACKET, master cylinder	1	
8	97016-06025	BOLT	2	
9	92906-06600	WASHER, plate	2	
10	90201-10118	WASHER, plate	4	
11	90401-10034	BOLT, union	2	
12	56A-26372-01	COVER, handle lever 1	1	

2VF010-8280

D7

FIG. 29 STAND, FOOTREST

REF. NO.	PART NO.	DESCRIPTION	Q'TY	REMARKS
1	1LR-27211-00	PEDAL, brake	1	
2	97003-06012	BOLT	1	
3	95303-06700	NUT	1	
4	90508-32468	SPRING, torsion	1	
5	99001-09600	CIRCLIP	1	
6	92902-12600	WASHER, plate	1	
7	39K-27231-00	ROD, brake	1	
8	90240-06040	PIN, clevis	1	
9	92901-06200	WASHER, plain	1	
10	91401-20015	PIN, cotter	1	
11	90501-10245	SPRING, compression	1	
12	90249-12008	PIN	1	
13	90175-06016	NUT, wing	1	
14	22W-27311-00-R4	STAND, side	1	BLACK (FOR ELECTRODEPOSIT)
15	22W-27321-00	BRACKET, side stand	1	
16	95811-10016	BOLT, flange	1	
17	90201-102A2	WASHER, plate	1	
18	90109-08666	BOLT	1	
19	90506-26270	SPRING, tension	1	
20	95303-08700	NUT	1	
21	22W-27411-01-90	FOOTREST 1	1	UNI CHROME (BLACK)
22	90508-20023	SPRING, torsion	1	
23	90249-08195	PIN	1	
24	91401-25015	PIN, cotter	1	
25	5X2-27422-01-33	BRACKET, footrest 2	1	YAMAHA BLACK
26	22W-27421-01-90	FOOTREST 2	1	UNI CHROME (BLACK)
27	90249-08195	PIN	1	
28	91401-25015	PIN, cotter	1	

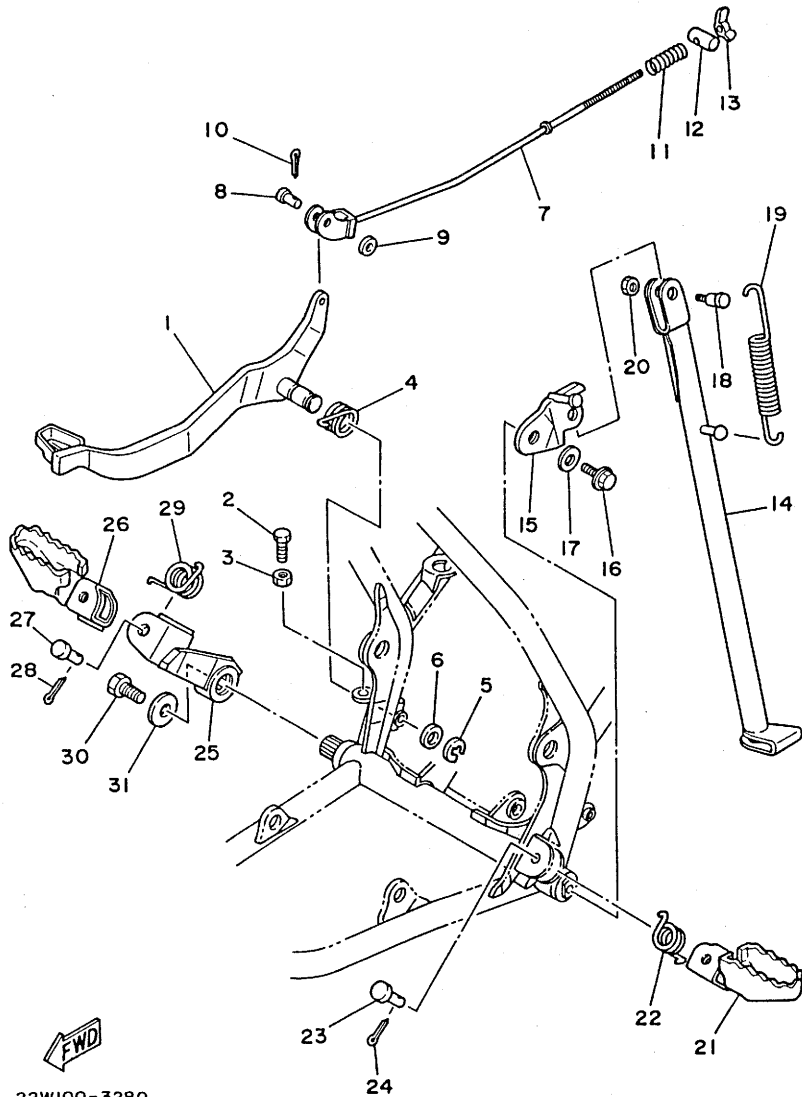

22W100-3280

D8

FIG. 29 STAND. FOOTREST

REF. NO.	PART NO.	DESCRIPTION	Q'TY	REMARKS
29	90508-20023	SPRING, torsion	1	
30	97011-10022	BOLT	1	
31	90201-10144	WASHER, plate	1	

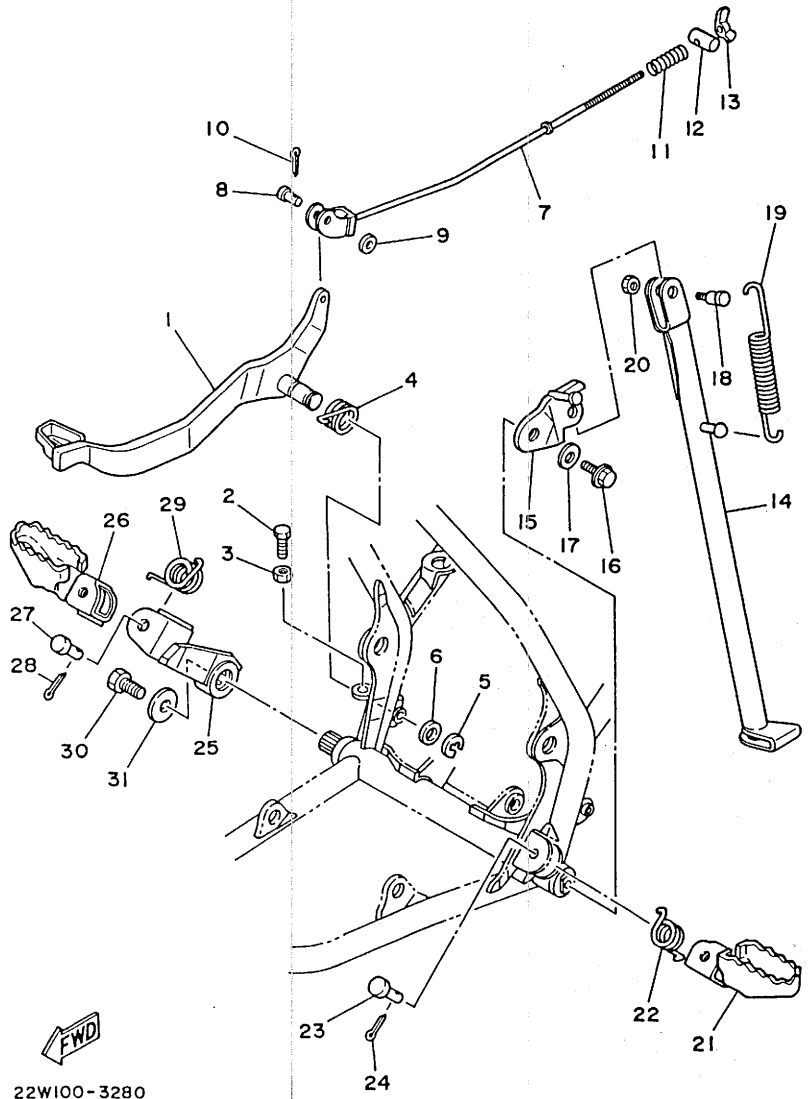

22W100-3280

D9

FIG. 30 GENERATOR

REF. NO.	PART NO.	DESCRIPTION	QTY	REMARKS
1	1LR-85510-20	STATOR ASSY	1	
2	39K-85512-20	.COIL, source	1	
3	39K-85580-20	.COIL, pulser	1	
4	98511-04025	.SCREW, pan head	2	
5	92902-04100	.WASHER, spring	2	
6	98503-04014	.SCREW, pan head	2	
7	92902-04100	.WASHER, spring	2	
8	98580-04008	.SCREW, pan head	1	
9	92902-04100	.WASHER, spring	1	
10	39K-85550-20	ROTOR ASSY	1	
11	92501-06014	SCREW, pan head	2	
12	92901-06600	WASHER, plate	2	
13	95311-10600	NUT	1	
14	90201-10774	WASHER, plate	1	
15	1LR-85540-20	C.D.I. UNIT ASSY	1	
16	2A7-85546-00	BAND	1	

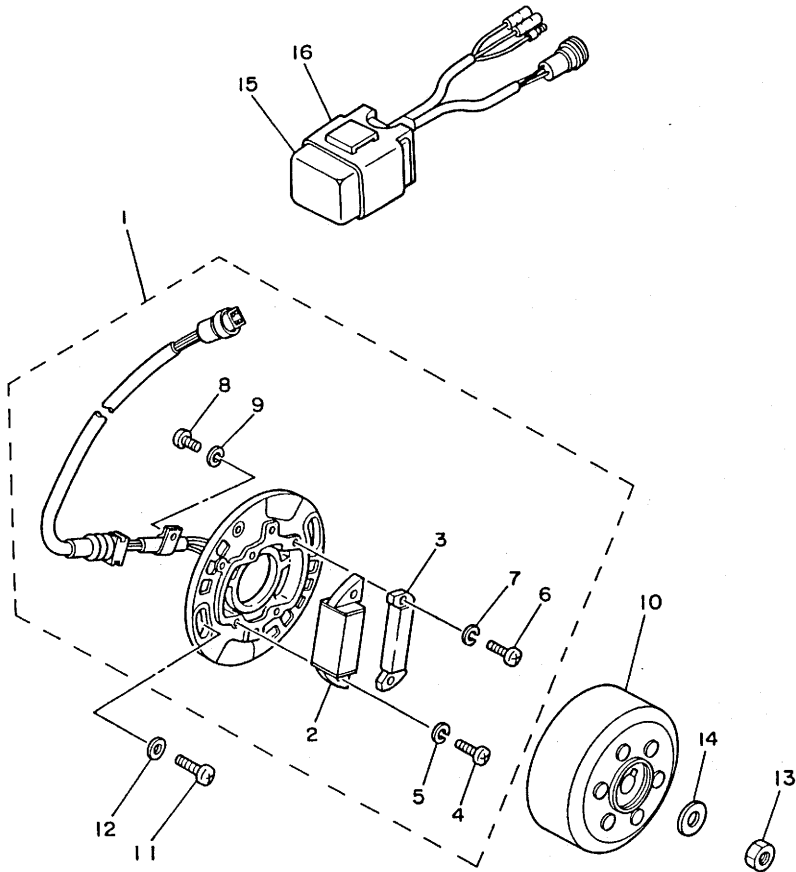

ILR100-6300

D10

FIG. 31 HANDLE SWITCH. LEVER

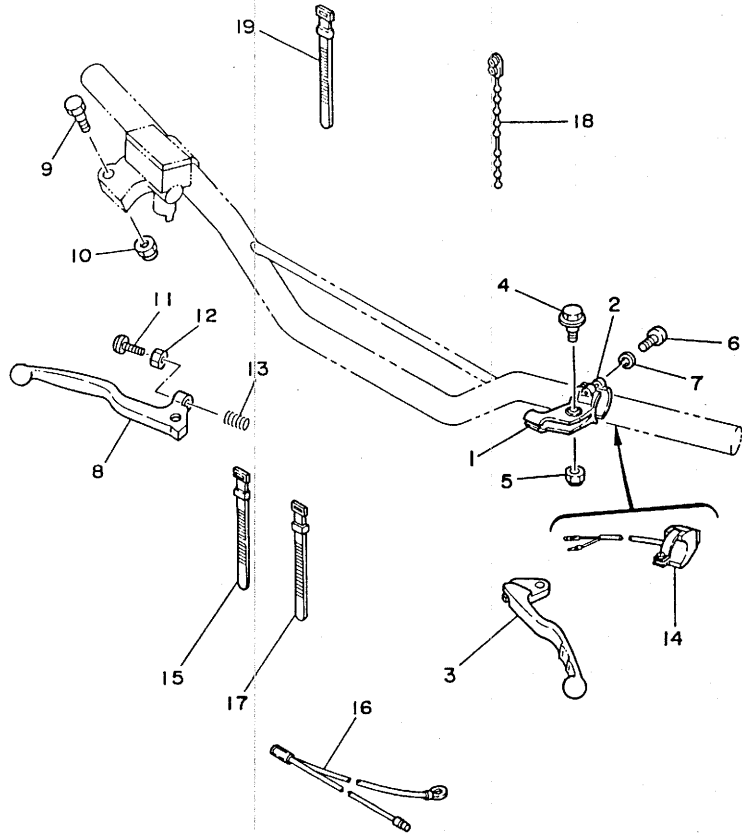

REF. NO.	PART NO.	DESCRIPTION	Q'TY	REMARKS
1	38V-82911-00	HOLDER, lever 1	1	
2	38V-82913-00	HOLDER, lever lower 1	1	
3	3R0-83912-01	LEVER 1	1	UR FOR U.S.A.
	23X-83912-00	LEVER 1	1	UR FOR CANADA, S.AFRICA, NEWZEALAND
4	90109-06799	BOLT	1	
5	95616-06100	NUT, u	1	
6	98506-05018	SCREW, pan head	2	
7	92906-05100	WASHER, spring	2	
8	1LR-83922-00	LEVER 2	1	UR FOR U.S.A.
	55Y-83922-00	LEVER 2	1	UR FOR CANADA, S.AFRICA, NEWZEALAND
9	90109-06577	BOLT	1	
10	95616-06100	NUT, u	1	
11	90149-06153	SCREW	1	
12	90170-06010	NUT	1	
13	90501-10312	SPRING, compression	1	
14	23X-83976-00	SWITCH, handle 1	1	
15	437-83936-01	BAND, switch cord	2	
16	5X1-82519-01	WIRE, earth lead	1	
17	437-83936-11	BAND, switch cord	1	
18	90464-20031	CLAMP	1	
19	25G-83936-01	BAND, switch cord	1	



2HF100-7310

D11

FIG. 32 ELECTRICAL 1

REF. NO.	PART NO.	DESCRIPTION	Q'TY	REMARKS
1	39K-82310-40	IGNITION COIL ASSY	1	
2	98501-06020	SCREW, pan head	2	
3	92990-06100	WASHER, spring	2	
4	3R0-82370-20	PLUG CAP ASSY	1	UR
	2TV-82370-00	PLUG CAP ASSY	1	UR WITH NOISE SUPPRESSOR

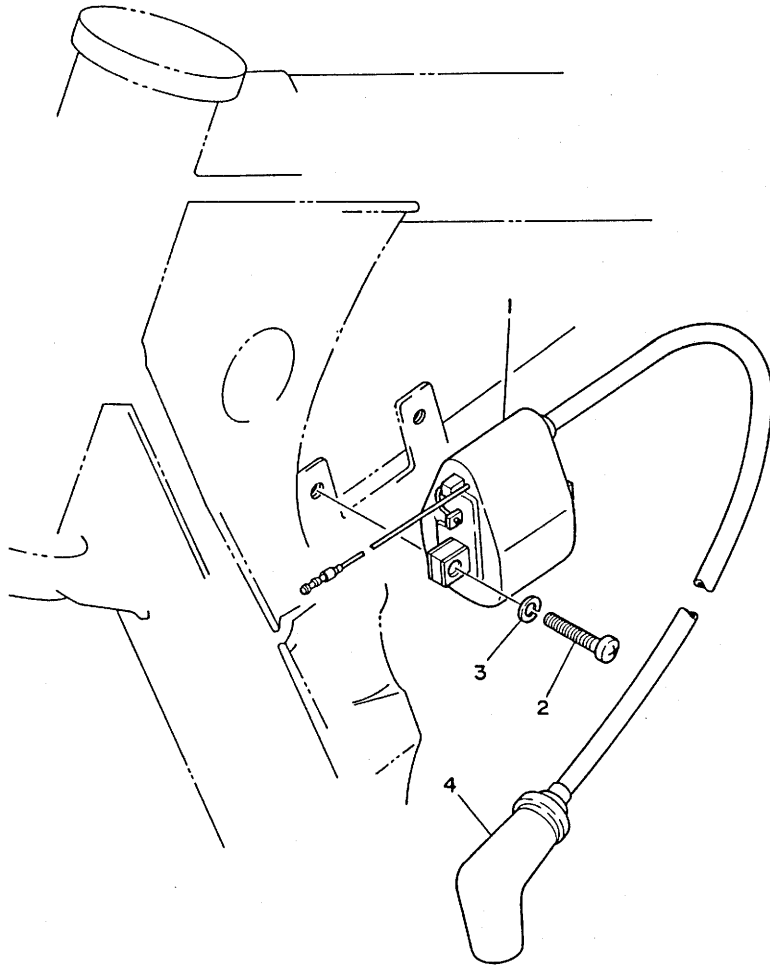

22W100-3291

D12

FIG. 33 ALTERNATE 1 (CHASSIS)

REF. NO.	PART NO.	DESCRIPTION	Q'TY	REMARKS
1	39K-23141-20	SPRING, front fork (K=0.25)	2	AP (HARD)
2	47J-23118-00	SPACER	2	AP
3	2HF-22212-20-P0	SPRING	1	UR (SOFT) VIVID MAGENTA SOLID
	2HF-22212-30-P0	SPRING	1	UR (HARD) VIVID MAGENTA SOLID

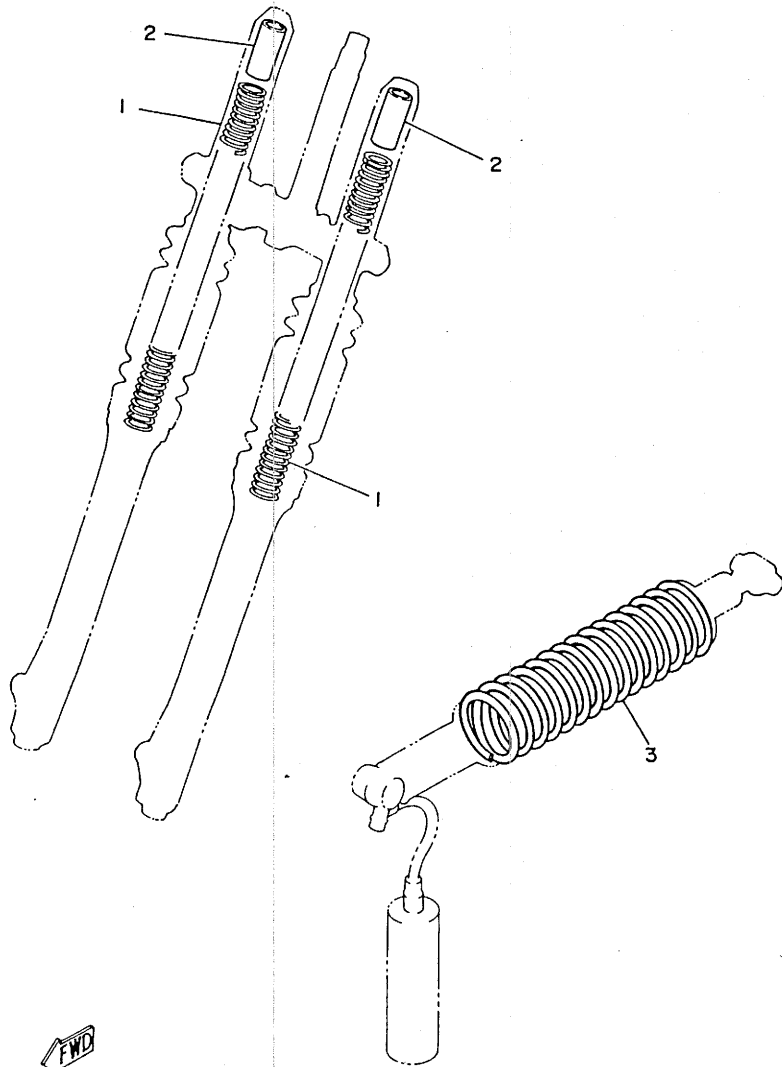

58T100-5310

D13

FIG. 34 REPAIR KIT

REF. NO.	PART NO.	DESCRIPTION	Q'TY	REMARKS
1	2VE-11630-A1	PISTON ASSY	1	AP
2	2VE-11631-00-94	.PISTON (STD)	1	
3	39K-11611-00	.RING, piston	1	
4	4V1-11633-00	.PIN, piston	1	
5	93450-13130	.CIRCLIP	2	
6	2VE-11630-E1	PISTON ASSY	1	AP
7	2VE-11635-00	.PISTON (0.25MM O/S)	1	
8	39K-11611-10	.RING, piston	1	
9	4V1-11633-00	.PIN, piston	1	
10	93450-13130	.CIRCLIP	2	
11	2VE-11630-F1	PISTON ASSY	1	AP
12	2VE-11636-00	.PISTON (0.50MM O/S)	1	
13	39K-11611-20	.RING, piston	1	
14	4V1-11633-00	.PIN, piston	1	
15	93450-13130	.CIRCLIP	2	
16	1LR-11650-00	CONNECTING ROD ASSY	1	AP
17	1LR-11651-00	.ROD, connecting	1	
18	93310-418M6	.BEARING, cylindrical	1	
19	4V0-11681-00	.PIN, crank 1	1	
20	90209-18112	.WASHER	2	
21	93310-312M5	.BEARING, cylindrical	1	

NUMERICAL INDEX

PART NO.	GRID NO.	PART NO.	GRID NO.	PART NO.	GRID NO.	PART NO.	GRID NO.	PART NO.	GRID NO.	PART NO.	GRID NO.
56A-W0041-00	D- 7	39K-12482-00	B- 5	39K-14718-00	B-10	39K-18512-00	C- 2	58T-23110-L0	C-11	10V-23416-01	C-10
2HF-W0046-00	D- 3	4V2-12494-00	B- 5	1LR-14753-00	B-10	4V0-18513-00	C- 2		C-11	22W-23435-00-35	C-10
1LR-W0047-00	D- 3	353-13115-01	B-11	3ML-14753-00	B-10	5X5-18531-01	C- 2	58T-23111-L0	C-11	35P-23441-00	C-10
51L-W0048-00	D- 3	1LR-13565-00	B- 6	565-14771-00	B-10	5X5-18535-01	C- 2		C-12	3MK-23485-00	C-10
1LR-W0057-00	D- 3	22W-13581-00	B- 6	58T-1490J-00	B- 8	22W-18540-00	C- 2	47J-23118-00	D-13	3MK-24110-00	C-13
2HF-W1441-00	B- 6	2HF-13610-01	B- 6	2VE-15111-00	B-11	2HF-21110-00-UJ	C- 4	58T-23118-L0	C-11	5X7-2412F-00	C-14
39K-W2535-00	D- 4	2HF-13613-00	B- 6	5X2-15113-01	B-11	3MK-21511-00	C- 5		C-12	1LR-24157-00	C-13
2VE-11111-00	B- 2	58T-13616-01	B- 6	2VE-15121-00	B-11	2VE-21523-00	C- 5	4H7-23119-00	C-11	22W-24158-00	C-13
1LR-11181-00	B- 2	1LR-13621-00	B- 6	4J2-15363-00	B-12	3MK-21611-00	C- 5		C-12	59V-24173-00	C-13
2HF-11311-01	B- 2	1LR-14101-00	B- 8	3AK-15383-01	B-15	39K-21620-01	C- 5	22W-2312K-00	C-11	22W-24181-00	C- 6
4V0-11351-00	B- 2	31J-14103-00	B- 8	2VE-15411-00	B-12	4V0-21621-00	C- 5		C-11	22W-24183-00	C-14
1LR-11400-00	B- 3	10W-14104-00	B- 9	2VE-15421-00	B-12	3MK-2165A-00	C- 5	22W-23125-L0	C-11	3MK-24244-00	C-14
39K-11412-00	B- 3	22W-14106-00	B- 8	22W-15451-01	B-12	3MK-21711-00	C- 6		C-12	3MK-24246-00	C- 6
39K-11422-00	B- 3	23L-14107-25	B- 8	5X2-15462-00	B-12	1LR-2172A-00	C- 6	2HF-23126-L0-35	C-11	3MK-24248-00	C- 6
39K-11611-00	B- 3	2X6-14112-25	B- 8	4V0-15618-00	B-13	3MK-21721-00-98	C- 6	122-23129-00	C-11	1LR-24311-00	C-14
	D-14	2X6-14112-30	B- 8	22W-15620-00	B-13	3MK-2173E-00	C- 6		C-12	2VE-24500-01	C-13
39K-11611-10	B- 3	2X6-14112-35	B- 8	4V0-15621-00	B-13	3MK-2173F-00	C- 6	2HF-23136-L0-35	C-11	4X8-24512-00	C-13
	D-14	3R1-14115-00	B- 8	4V0-15641-00	B-13	1LR-2174F-00	C- 6	39K-23141-00	C-11	4X8-24534-00	C-13
39K-11611-20	B- 3	2A6-14126-00	B- 9	4V0-15651-00	B-13	3MK-21741-00	C- 6		C-12	5X7-24611-01	C-13
	D-14	248-14131-00	B- 9	22W-15660-00	B-13	22W-21791-00	C- 6	39K-23141-20	D-13	5X7-24612-00	C-13
2VE-11630-A1	D-14	3R1-14141-50	B- 8	4V0-15664-00	B-13	2VE-22110-00	C- 7	583-23142-00	C-11	3MK-24731-00	C-15
2VE-11630-E1	D-14	3R1-14141-52	B- 8	1LR-16111-00	B-14	22W-22124-00	C- 7		C-12	3MK-24770-00	C-15
2VE-11630-F1	D-14	3R1-14141-54	B- 8	1LR-16150-00	B-14	401-22127-00	C- 7	22W-23144-L0	C-11	1LR-25104-00	D- 2
2VE-11631-00-94	B- 3	260-14142-30	B- 8	4V0-16154-00	B-14	401-22128-01	C- 7		C-12	1LR-25111-00-98	D- 2
	D-14	260-14142-35	B- 8	21V-16321-00	B-14	22W-22129-00	C- 8	22W-23145-L0	C-11	462-25118-00	D- 2
2VE-11631-00-95	B- 3	260-14142-40	B- 8	257-16324-00	B-14		C- 9		C-12	4NO-25151-00	D- 4
4V1-11633-00	B- 3	137-14143-54-A1	B- 8	1LR-16351-00	B-14	5X6-22129-00	C- 7	22W-23146-L0	C-11	22W-25181-01	D- 2
	D-14	137-14143-56-A0	B- 8	137-16356-00	B-14	4V1-22141-00	C- 7		C-12	1T1-25194-00	D- 2
	D-14	137-14143-58-A1	B- 8	2X3-16357-00	B-14	1LR-22151-00	C- 7	509-23151-L0	C-11	39K-25304-00	D- 4
	D-14	137-14143-60-A0	B- 8	1LR-16371-00	B-14	39K-2217A-00	C- 7		C-12	39K-25311-00-98	D- 4
2VE-11635-00	B- 3	132-14146-00	B- 9	58T-16382-00	B-14	22W-2217F-00	C- 8	22W-23153-L0	C-11	39K-25321-00-98	D- 4
	D-14	39K-14153-00	B- 8	2VE-17121-00	B-15	30X-22178-00	C- 4		C-12	51L-2533A-00	D- 5
2VE-11636-00	B- 3	2A6-14158-00	B- 9	2VE-17131-00	B-15	4V4-22184-00	C- 4	22W-23157-L0	C-11	3R0-25355-11	D- 4
	D-14	3X3-14169-00	B- 8	2VE-17151-00	B-15	22W-22189-00	C- 9		C-12	1LR-25381-01	D- 4
1LR-11650-00	D-14	4U5-14171-00	B- 9	2VE-17161-00	B-15	39K-22199-00	C- 7	509-23158-L0	C-11	2HF-25388-00	D- 5
1LR-11651-00	B- 3	304-14184-00	B- 8	4V0-17211-00	B-15	2HF-22201-00	C- 9		C-12	5X2-25394-00	D- 4
	D-14	314-14185-00	B- 8	39K-17221-00	B-15	3MK-22210-00-PO	C- 9	39K-23170-L0	C-11	39K-25444-01	D- 4
4V0-11681-00	B- 3	127-14186-00	B- 8	4V0-17231-00	B-15	3ML-22210-00-PO	C- 9		C-11	39K-25446-00	D- 4
	D-14	53V-14196-00	B- 8	39K-17241-00	B-15	2HF-22212-00-PO	C- 9	39K-23173-00	C-11	39K-25448-00	D- 4
2VE-12422-00	B- 4	2HF-14451-00	B- 6	39K-17251-01	B-15	2HF-22212-20-PO	D-13		C-11	39K-25450-01	D- 4
5X2-12428-00	B- 4	2HF-14452-00	C- 6	39K-17261-01	B-15	2HF-22212-30-PO	D-13	278-23181-50	C-11	3MK-25807-00	D- 3
2VE-12446-00	B- 5	2HF-14453-00	B- 6	2VE-17411-00	B-15	22W-22214-01	C- 9		C-12	1LR-25831-00	D- 3
22W-12450-00	B- 4	39K-14457-00	B- 6	22W-17421-00	B-15	2X6-22216-00	C- 9	58T-23184-L0	C-11	34X-25845-00	D- 3
1LR-12459-00	B- 4	2HF-14458-00	B- 6	164-17427-00-06	B-15	22W-22223-00	C- 9		C-12	2VN-25852-00	D- 7
2HF-12460-00	B- 5	2HF-14459-00	B- 6	22W-18101-00	C- 3	24X-22261-00	C- 9	39K-23340-L0	C-12	56A-25854-00	D- 7
22W-12462-00	B- 5	2HF-14462-00	B- 6	2HF-18110-00	C- 3	24X-22262-00	C- 9	3R4-23389-00	C-10	56A-25867-00	D- 7
22W-12463-00	B- 5	2HF-14477-00	B- 6	22W-18140-00	C- 2	2HF-23102-L0	C-11	122-23411-00	C-10	2VN-25870-00	D- 7
39K-12481-00	B- 5	2HF-14610-01	B-10	4V0-18511-00	C- 2	2HF-23103-L0	C-11	122-23412-00	C-10	2HF-25872-00	D- 7

NUMERICAL INDEX

PART NO.	GRID NO.	PART NO.	GRID NO.	PART NO.	GRID NO.	PART NO.	GRID NO.	PART NO.	GRID NO.	PART NO.	GRID NO.
56A-25919-00	D- 3	90101-08699	D- 5	90201-08085	B- 4	90387-126F8	D- 2	91011-08125	C- 4	93102-20231	B- 3
56A-25919-10	D- 3	90105-14102	C-10	90201-08087	B- 2	90387-126R2	D- 5	91011-08135	C- 4	93103-10147	B- 4
56A-25926-00	D- 3	90109-063F7	C- 2	90201-081A6	D- 4	90387-127J7	C- 7	91021-08030	C-10	93103-28126	B- 3
5R2-25937-00	D- 3	90109-06577	D-11	90201-08730	C- 5	90387-127J8	C- 7	91021-08045	C- 7	93106-18013	D- 2
56A-25937-00	D- 3	90109-06799	D-11	90201-100E9	C- 7	90387-202F0	B-14	91311-06016	C-10	93106-20002	D- 4
2HF-26111-00-35	D- 6	90109-08666	D- 8	90201-10118	D- 7	90387-22647	D- 6	91401-20015	D- 8	93109-12012	C- 3
1LX-26241-01	D- 6	90109-08706	D- 4	90201-10144	D- 9	90401-10034	D- 7	91401-25015	D- 7	93109-14021	B-14
1LX-26242-01	D- 6	90109-100E4	C- 7	90201-102A2	D- 8	90430-06016	B-12		D- 8	93109-15001	B-13
22W-26243-00	D- 6	90109-10688	C- 8	90201-10614	B- 4	90430-06166	B- 4	92501-06014	C- 6	93109-16035	C- 8
5X2-2628H-01	D- 6	90109-10689	C- 8	90201-10774	D-10	90201-10774	B-11		C- 6	93109-17048	C- 7
5X2-26281-00	D- 6		C- 9	90201-12M34	B-13	90445-08376	B-11		D-10	93210-14104	B-12
322-26282-00	D- 6	90109-10729	C- 9	90201-120A5	C- 7	90445-09304	C-13	92506-06016	B- 5	93210-16275	B- 5
22W-26311-00	D- 6	90116-08402	B- 2	90201-122A7	D- 2	90445-164E1	B- 6	92506-06025	B-12	93210-18288	B- 8
39K-26335-01	D- 6	90119-06063	C- 5	90201-124G9	C- 7	90450-22017	B- 5	92506-06060	B- 4	93210-40745	B-10
382-26372-01	D- 6	90119-06085	B- 7	90201-12631	B-13	90450-28014	B- 5	92516-06030	B-12	93306-00105	D- 2
56A-26372-01	D- 7	90122-06013	B- 6	90201-14411	B-14	90460-43053	B- 6	92701-06012	B-15		D- 4
1LR-27211-00	D- 8	90123-08013	D- 6	90201-154A1	B-13	90460-51059	B- 6	92901-06200	D- 8	93306-00108	D- 4
39K-27231-00	D- 8	90149-06011	C-13	90201-191J4	C- 7	90464-20031	D-11	92901-06600	B-10	93306-20333	B-15
22W-27311-00-R4	D- 8	90149-06153	D-11	90202-06010	B-10	90465-14242	C-10		C-10	93306-20401	B-15
22W-27321-00	D- 8	90149-06248	D- 3		C-13	90467-08004	B- 5		D-10	93306-20454	B- 3
22W-27411-01-90	D- 8	90159-05011	B-14	90208-12015	B-14	90467-10008	C-14	92901-06700	C- 4	93306-30101	D- 4
22W-27421-01-90	D- 8	90159-05101	C- 6		B-14	90467-16063	B- 6	92902-04100	B- 8	93310-312M5	B- 3
5X2-27422-01-33	D- 8	90159-06013	C- 6	90209-06096	B- 6	90468-26046	B-13		D-10		D-14
10V-28135-00	C- 4	90159-06032	C- 6	90209-06187	C- 5	90480-12053	C- 6		D-10	93310-418M6	B- 3
39K-82310-40	D-12	90159-06033	B- 6	90209-18112	B- 3	90480-15064	B- 5		D-10		D-14
2TV-82370-00	D-12	90159-06060	C-10		D-14	90480-17359	C- 9	92902-12600	C- 9	93315-21429	B-14
3R0-82370-20	D-12	90170-06010	D-11	90240-06040	D- 8	90480-18290	C-13	92906-05100	D-11	93315-31502	B-15
5X1-82519-01	D-11	90175-06016	D- 8	90249-08195	D- 8		C-13	92906-06600	B-12	93317-11245	B-15
688-82535-00	D- 6	90176-08026	B- 2		D- 8	90501-10245	D- 8		D- 7	93317-21746	C- 7
38V-82911-00	D-11	90179-08148	D- 6	90249-12008	D- 8	90501-10312	D-11	92990-03100	B- 6	93332-00059	C-10
38V-82913-00	D-11	90179-12244	B-14	90250-06013	C- 2	90501-12081	B-13	92990-06100	B- 5	93410-20038	B-15
23X-83912-00	D-11	90179-12335	B-14	90280-03045	B- 3	90501-204A0	B-14		B- 6	93430-08007	B-13
3R0-83912-01	D-11	90179-25033	C-10	90282-05001	B-14	90504-03033	B- 6		B-10	93440-15012	B-15
1LR-83922-00	D-11	90185-10120	C- 7	90338-07011	B-11	90506-14081	D- 4		C- 5	93440-17064	B-15
55Y-83922-00	D-11		C- 8	90340-12059	B-11	90506-26270	D- 8		C- 6	93440-42101	C- 9
25G-83936-01	D-11		C- 8	90380-12094	C- 7	90507-20030	B-10		C- 6	93450-13130	B- 3
437-83936-01	C- 5		C- 9	90380-16109	C- 7	90508-18463	B-14		C-13		D-14
	B- 5		C- 9	90381-08002	B- 4	90508-20023	D- 8		C-13		D-14
	D-11	90185-12046	D- 2	90383-16023	C- 8		D- 9		C-13		D-14
	D-11	90185-12119	C- 7		C- 8	90508-26464	B-13		C-13	93503-16010	B-14
437-83936-11	D-11		C- 7		C- 7	90508-26561	C- 2		C-14		C-10
23X-83976-00	D-11	90201-06067	C- 7	90384-18190	C- 7	90508-32468	D- 8		D-12	93507-32031	B-13
1LR-85510-20	D-10	90201-06072	C-13	90385-17042	C- 7	90508-32642	C- 3	92990-08100	C-12	93603-22028	B- 4
39K-85512-20	D-10		C-13	90387-07392	B- 5	90508-32642	C- 3	92990-10600	C- 8	93604-10011	B- 4
1LR-85540-20	D-10	90201-061H3	B- 5	90387-07598	C-13	90560-12257	D- 2		C- 8	93608-30152	C- 3
2A7-85546-00	D-10	90201-065F3	C- 5		C-13	90560-12320	D- 4		C- 8	93822-12012	B-15
39K-85550-20	D-10	90201-06571	C- 6	90387-105G9	C- 8	91001-08020	C- 5		C- 9	93822-13024	B-15
39K-85580-20	D-10		C- 6	90387-106G0	C- 8	91001-08025	C- 5		C- 9		B-15
90101-06278	D- 4	90201-067A0	C- 4		C- 9	91001-08035	C-10	93102-20143	B-15	93822-14037	B-15

NUMERICAL INDEX

PART NO.	GRID NO.	PART NO.	GRID NO.	PART NO.	GRID NO.	PART NO.	GRID NO.	PART NO.	GRID NO.
93822-15065	B-15	98501-06012	C-14						
94107-177R6	D- 2	98501-06020	D-12						
94109-147R7	D- 4	98501-06035	B-11						
94208-17255	D- 2	98502-06016	C- 5						
94232-14174	D- 4	98503-03008	C-13						
94327-14076	D- 4	98503-04014	D-10						
94332-17112	D- 2	98503-06045	B-11						
94414-17428	D- 2	98506-05016	D- 6						
94416-14375	D- 4	98506-05018	D-11						
94580-24112	D- 5	98506-06008	B-12						
94680-24001	D- 5	98506-06040	B-12						
94702-00324	B- 2	98511-04016	B- 8						
94702-00325	B- 2	98511-04025	D-10						
95023-08012	C- 4	98516-06020	B- 4						
95026-06020	B- 6	98580-03008	B- 6						
95026-06025	C- 7	98580-04008	D-10						
95303-06600	D- 4	98706-04012	D- 6						
95303-06700	D- 8		D- 7						
95303-08700	D- 5	98903-06010	C- 6						
	D- 8	98906-06008	B-10						
95311-10600	D-10	98980-06020	C-13						
95601-05100	B- 6	99001-09600	D- 8						
95601-08200	C- 4	99006-10600	C- 3						
	C- 5	99009-12400	B-13						
	C- 7	99009-18400	B-15						
95601-12200	D- 4	99080-07600	B- 4						
95611-08100	D- 4	99510-10114	B- 2						
95616-06100	D-11	99510-12016	B-11						
	D-11	99530-10014	B-12						
95702-10500	B-13								
95811-08035	D- 3								
95811-10016	D- 8								
95826-06020	B- 4								
97001-06030	B- 5								
97003-06012	C-13								
	C-13								
	D- 8								
97011-06020	C- 3								
97011-10022	D- 9								
97013-06012	B- 6								
97016-06025	D- 7								
97021-06030	C-13								
	C-13								
97313-06016	B-10								
	C- 4								
97313-08040	C-12								
98501-04006	C- 9								
98501-06012	B-11								

1. 1. 1.

1. 1. 1.

